

# GE HN AJ

Hrdlo k naskrutkovaniu

**HANSA FLEX**

## Vlastnosti

Prípojka 1	Vonkajší závit NPT
Tvar tesnenia 1	tesniaci závit
Prípojka 2	Závit pre matice UN/UNF
Tvar tesnenia 2	Vnútorňý kužeľ 74°
Konštrukcia	Hrdlo k zaskrutkovaniu
Vyhotovenie	priame
Materiál	Oceľ
Povrchová ochrana	galvanický povlak

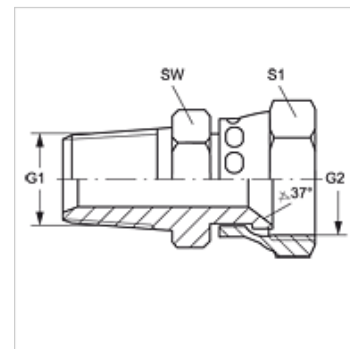

## Výrobok

Označenie	G1	G2	SW (mm)	S1
GE HN 02 AJ 04	1/8" -27 NPT	7/16" -20 UNF	14	14
GE HN 02 AJ 05	1/8" -27 NPT	1/2" -20 UNF	14	17
GE HN 02 AJ 06	1/8" -27 NPT	9/16" -18 UNF	17	14
GE HN 04 AJ	1/4" -18 NPT	7/16" -20 UNF	14	14
GE HN 04 AJ 05	1/4" -18 NPT	1/2" -20 UNF	16	16
GE HN 04 AJ 06	1/4" -18 NPT	9/16" -18 UNF	17	17
GE HN 04 AJ 08	1/4" -18 NPT	3/4" -16 UNF	19	22
GE HN 06 AJ	3/8" -18 NPT	9/16" -18 UNF	19	17
GE HN 06 AJ 08	3/8" -18 NPT	3/4" -16 UNF	22	22
GE HN 06 AJ 10	3/8" -18 NPT	7/8" -14 UNF	22	27
GE HN 08 AJ 06	1/2" -14 NPT	9/16" -18 UNF	25	19
GE HN 08 AJ	1/2" -14 NPT	3/4" -16 UNF	22	22
GE HN 08 AJ 10	1/2" -14 NPT	7/8" -14 UNF	25	25
GE HN 08 AJ 12	1/2" -14 NPT	1.1/16" -12 UN	27	32
GE HN 12 AJ 08	3/4" -14 NPT	3/4" -16 UNF	27	22
GE HN 12 AJ 10	3/4" -14 NPT	7/8" -14 UNF	32	27
GE HN 12 AJ	3/4" -14 NPT	1.1/16" -12 UN	27	32
GE HN 12 AJ 14	3/4" -14 NPT	1,3/16" -12 UN	27	32
GE HN 12 AJ 16	3/4" -14 NPT	1,5/16" -12 UN	32	38
GE HN 16 AJ	1" -11,5 NPT	1,5/16" -12 UN	36	38
GE HN 16 AJ 20	1" -11,5 NPT	1,5/8" -12 UN	36	50
GE HN 20 AJ	1,1/4" -11,5 NPT	1,5/8" -12 UN	46	50
GE HN 24 AJ	1,1/2" -11,5 NPT	1,7/8" -12 UN	58	58

SW, S1, S2 = Šírka kľúča

## Varianty produktu

GE HN AJ VA Hrdlo k naskrutkovaniu, Ušľachtilá oceľ