

GE HR

Hrdlo k naskrutkovaniu

HANSA FLEX

Vlastnosti

Prípojka 1	Vonkajší závit BSP, valcový
Tvar tesnenia 1	Tvar A
Prípojka 2	Vonkajší závit BSP, valcový
Tvar tesnenia 2	Tvar A
Konštrukcia	Hrdlo k zaskrutkovaniu
Vyhotovenie	priame
Materiál	Oceľ
Povrchová ochrana	galvanický povlak

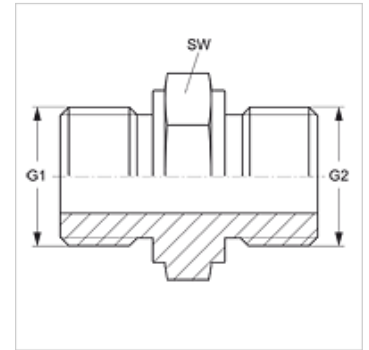

Výrobok

Označenie	G1	G2	SW (mm)
GE HR 04	G 1/4" -19	G 1/4" -19	19
GE HR 06 HR 04	G 3/8" -19	G 1/4" -19	22
GE HR 06	G 3/8" -19	G 3/8" -19	22
GE HR 08 HR 06	G 1/2" -14	G 3/8" -19	27
GE HR 08	G 1/2" -14	G 1/2" -14	27
GE HR 12 HR 08	G 3/4" -14	G 1/2" -14	32
GE HR 12	G 3/4" -14	G 3/4" -14	32

SW = Šírka kľúča