

Vlastnosti

| | |
|-------------------|-----------------------------|
| Prípojka 1 | Vonkajší závit BSP, valcový |
| Tvar tesnenia 1 | Tvar E |
| Prípojka 2 | Vonkajší závit UN/UNF |
| Tvar tesnenia 2 | Vonkajší kužeľ 74° |
| Konštrukcia | Hrdlo k zaskrutkovaniu |
| Vyhotovenie | priame |
| Materiál | Oceľ |
| Povrchová ochrana | galvanický povlak |

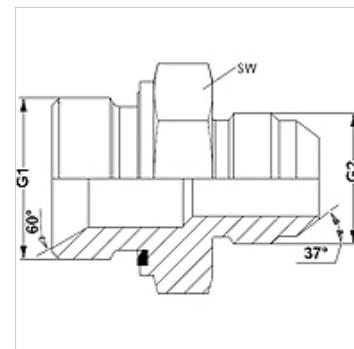

Výrobok

| Označenie | G1 | G2 | SW (mm) |
|------------------|--------------|----------------|------------|
| GE HRED 02 HJ 04 | G 1/8" -28 | 7/16" -20 UNF | 14 |
| GE HRED 02 HJ 05 | G 1/8" -28 | 1/2" -20 UNF | 14 |
| GE HRED 02 HJ 06 | G 1/8" -28 | 9/16" -18 UNF | 19 |
| GE HRED 04 HJ | G 1/4" -19 | 7/16" -20 UNF | 19 |
| GE HRED 04 HJ 05 | G 1/4" -19 | 1/2" -20 UNF | 19 |
| GE HRED 04 HJ 06 | G 1/4" -19 | 9/16" -18 UNF | 19 |
| GE HRED 04 HJ 08 | G 1/4" -19 | 3/4" -16 UNF | 19 |
| GE HRED 06 HJ 04 | G 3/8" -19 | 7/16" -20 UNF | 22 |
| GE HRED 06 HJ 05 | G 3/8" -19 | 1/2" -20 UNF | 22 |
| GE HRED 06 HJ | G 3/8" -19 | 9/16" -18 UNF | 22 |
| GE HRED 06 HJ 08 | G 3/8" -19 | 3/4" -16 UNF | 22 |
| GE HRED 06 HJ 10 | G 3/8" -19 | 7/8" -14 UNF | 24 |
| GE HRED 06 HJ 12 | G 3/8" -19 | 1.1/16" -12 UN | 27 |
| GE HRED 08 HJ 04 | G 1/2" -14 | 7/16" -20 UNF | 27 |
| GE HRED 08 HJ 06 | G 1/2" -14 | 9/16" -18 UNF | 27 |
| GE HRED 08 HJ | G 1/2" -14 | 3/4" -16 UNF | 27 |
| GE HRED 08 HJ 10 | G 1/2" -14 | 7/8" -14 UNF | 27 |
| GE HRED 08 HJ 12 | G 1/2" -14 | 1.1/16" -12 UN | 27 |
| GE HRED 12 HJ 08 | G 3/4" -14 | 3/4" -16 UNF | 32 |
| GE HRED 12 HJ 10 | G 3/4" -14 | 7/8" -14 UNF | 32 |
| GE HRED 12 HJ | G 3/4" -14 | 1.1/16" -12 UN | 32 |
| GE HRED 12 HJ 16 | G 3/4" -14 | 1.5/16" -12 UN | 36 |
| GE HRED 16 HJ 12 | G 1" -11 | 1.1/16" -12 UN | 41 |
| GE HRED 16 HJ | G 1" -11 | 1.5/16" -12 UN | 41 |
| GE HRED 16 HJ 20 | G 1" -11 | 1.5/8" -12 UN | 46 |
| GE HRED 16 HJ 24 | G 1" -11 | 1.7/8" -12 UN | 50 |
| GE HRED 20 HJ 16 | G 1,1/4" -11 | 1.5/16" -12 UN | 50 |
| GE HRED 20 HJ | G 1,1/4" -11 | 1.5/8" -12 UN | 50 |
| GE HRED 20 HJ 24 | G 1,1/4" -11 | 1.7/8" -12 UN | 50 |
| GE HRED 24 HJ 20 | G 1,1/2" -11 | 1.5/8" -12 UN | 55 |
| GE HRED 24 HJ | G 1,1/2" -11 | 1.7/8" -12 UN | 55 |

SW = Šírka kľúča

Varianty produktu

GE HRED HJ VA Hrdlo k naskrutkovaniu, Ušľachtilá oceľ

Náhradné diely

WD Mäkké tesnenie pre nákrutky ED