

Vlastnosti

Prípojka 1	Vonkajší závit kužeľový BSPT
Tvar tesnenia 1	tesniaci závit
Prípojka 2	Závit pre matice BSP
Tvar tesnenia 2	Vnútorň kužeľ 60°
Konštrukcia	Hrdlo k zaskrutkovaniu
Vyhotovenie	priame
Materiál	Oceľ
Povrchová ochrana	galvanický povlak

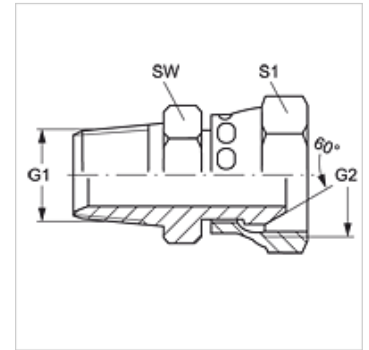

Výrobok

Označenie	G1	G2	SW (mm)	S1
GE HRK 02 AB	R 1/8" K	G 1/8" -28	14	14
GE HRK 04 AB	R 1/4" K	G 1/4" -19	19	19
GE HRK 06 AB	R 3/8" K	G 3/8" -19	22	22
GE HRK 06 AB 08	R 3/8" K	G 1/2" -14	22	27
GE HRK 08 AB 06	R 1/2" K	G 3/8" -19	27	22
GE HRK 08 AB	R 1/2" K	G 1/2" -14	27	27
GE HRK 10 AB	R 5/8" K	G 5/8" -14	30	30
GE HRK 12 AB 08	R 3/4" K	G 1/2" -14	37	27
GE HRK 12 AB	R 3/4" K	G 3/4" -14	37	37
GE HRK 16 AB 12	R 1" K	G 3/4" -14	41	37
GE HRK 16 AB	R 1" K	G 1" -11	41	41
GE HRK 20 AB	R 1,1/4" K	G 1,1/4" -11	50	50
GE HRK 24 AB	R 1,1/2" K	G 1,1/2" -11	55	60
GE HRK 32 AB	R 2" K	G 2" -11	64	67

SW, S1, S2 = Šírka kľúča

Varianty produktu

GE HRK AB VA Hrdlo k nasrnutkovaniu, Ušľachtilá oceľ