

Vlastnosti

Prípojka 1	Vonkajší závit kužeľový BSPT
Tvar tesnenia 1	tesniaci závit
Prípojka 2	Vnútorný závit BSP, valcový
Tvar tesnenia 2	s plochým tesnením
Konštrukcia	Hrdlo k zaskrutkovaniu
Vyhotovenie	priame
Materiál	Oceľ
Povrchová ochrana	galvanický povlak

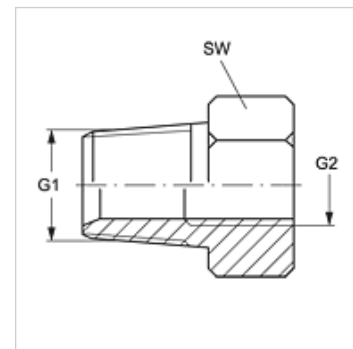

Výrobok

Označenie	G1	G2	SW (mm)
GE HRK 02 IR 04	R 1/8" K	G 1/4" -19	19
GE HRK 02 IR 06	R 1/8" K	G 3/8" -19	22
GE HRK 02 IR 08	R 1/8" K	G 1/2" -14	27
GE HRK 04 IR 02	R 1/4" K	G 1/8" -28	14
GE HRK 04 IR	R 1/4" K	G 1/4" -19	19
GE HRK 04 IR 06	R 1/4" K	G 3/8" -19	22
GE HRK 04 IR 08	R 1/4" K	G 1/2" -14	27
GE HRK 06 IR 02	R 3/8" K	G 1/8" -28	19
GE HRK 06 IR 04	R 3/8" K	G 1/4" -19	19
GE HRK 06 IR	R 3/8" K	G 3/8" -19	22
GE HRK 06 IR 08	R 3/8" K	G 1/2" -14	27
GE HRK 08 IR 04	R 1/2" K	G 1/4" -19	22
GE HRK 08 IR 06	R 1/2" K	G 3/8" -19	22
GE HRK 08 IR	R 1/2" K	G 1/2" -14	27
GE HRK 08 IR 12	R 1/2" K	G 3/4" -14	36
GE HRK 08 IR 16	R 1/2" K	G 1" -11	41
GE HRK 12 IR 04	R 3/4" K	G 1/4" -19	27
GE HRK 12 IR 06	R 3/4" K	G 3/8" -19	27
GE HRK 12 IR 08	R 3/4" K	G 1/2" -14	27
GE HRK 12 IR	R 3/4" K	G 3/4" -14	32
GE HRK 12 IR 16	R 3/4" K	G 1" -11	41
GE HRK 16 IR 08	R 1" K	G 1/2" -14	36
GE HRK 16 IR 12	R 1" K	G 3/4" -14	36
GE HRK 16 IR	R 1" K	G 1" -11	41
GE HRK 16 IR 20	R 1" K	G 1,1/4" -11	50
GE HRK 20 IR 08	R 1,1/4" K	G 1/2" -14	50
GE HRK 20 IR 12	R 1,1/4" K	G 3/4" -14	50
GE HRK 20 IR 16	R 1,1/4" K	G 1" -11	50
GE HRK 20 IR 24	R 1,1/4" K	G 1,1/2" -11	55
GE HRK 24 IR 16	R 1,1/2" K	G 1" -11	55
GE HRK 24 IR 20	R 1,1/2" K	G 1,1/4" -11	55
GE HRK 24 IR 32	R 1,1/2" K	G 2" -11	70
GE HRK 32 IR 20	R 2" K	G 1,1/4" -11	70
GE HRK 32 IR 24	R 2" K	G 1,1/2" -11	70

SW = Šírka kľúča