

GE O AN

Hrdlo k nasrútkovaniu

HANSA FLEX

Vlastnosti

| | |
|-------------------|---|
| Prípojka 1 | Vonkajší závit UN/UNF |
| Tvar tesnenia 1 | Tesnenie O-krúžkom na hrdle k nasrútkovaniu |
| Prípojka 2 | Závit pre matice NPSM |
| Tvar tesnenia 2 | Vonkajší kužeľ 60° |
| Konštrukcia | Hrdlo k zasrútkovaniu |
| Vyhotovenie | priame |
| Materiál | Oceľ |
| Povrchová ochrana | galvanický povlak |

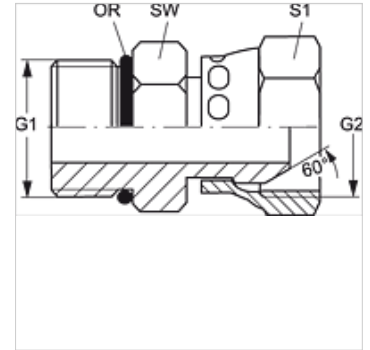

Výrobok

| Označenie | G1 | G2 | SW (mm) | S1 | OR |
|---------------|----------------|--------------|------------|----|--------------|
| GE O 04 AN | 7/16" -20 UNF | 1/4" -18 NPT | 14 | 18 | 8,92 x 1,83 |
| GE O 06 AN | 9/16" -18 UNF | 3/8" -18 NPT | 18 | 22 | 11,90 x 1,98 |
| GE O 06 AN 08 | 9/16" -18 UNF | 1/2" -14 NPT | 19 | 25 | 11,90 x 1,98 |
| GE O 08 AN | 3/4" -16 UNF | 1/2" -14 NPT | 22 | 25 | 16,36 x 2,20 |
| GE O 08 AN 12 | 3/4" -16 UNF | 3/4" -14 NPT | 25 | 32 | 16,36 x 2,20 |
| GE O 10 AN 06 | 7/8" -14 UNF | 3/8" -18 NPT | 22 | 25 | 19,18 x 2,46 |
| GE O 10 AN 08 | 7/8" -14 UNF | 1/2" -14 NPT | 25 | 25 | 19,18 x 2,46 |
| GE O 12 AN 08 | 1.1/16" -12 UN | 1/2" -14 NPT | 32 | 25 | 23,47 x 2,95 |
| GE O 12 AN | 1.1/16" -12 UN | 3/4" -14 NPT | 32 | 32 | 23,47 x 2,95 |
| GE O 16 AN | 1,5/16" -12 UN | 1" -11,5 NPT | 38 | 38 | 29,74 x 2,95 |

SW, S1, S2 = Šírka kľúča