

PA 500 AOB VA

Armatúra k nalisovaniu, DKOR

HANSA FLEX

Vlastnosti

Oblasť použitia	Armatúra k nalisovaniu pre hadice HD 500
Prípojka 1	Závit pre matice BSP
Tvar tesnenia 1	Vonkajší kužel 60° s O-krúžkom
Skratka	DKOR
Norma	ISO 8434-6 BS 5200
Zapojenie	s ochranou proti vytrhnutiu (Interlock)
Rozsah dodávky	Vsuvka k nalisovaniu + objímka k nalisovaniu
Materiál	Ušľachtilá oceľ

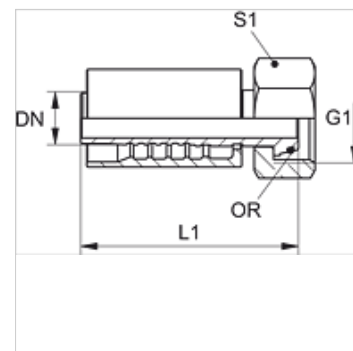

Výrobok

Označenie	DN	Rozmer	Clo	G1	S1	OR
PA 520 AOB VA	19	12	3/4"	G 3/4" -14	32	17,1 x 1,6
PA 525 AOB VA	25	16	1"	G 1" -11	41	22,1 x 1,6
PA 532 AOB VA	31	20	1.1/4"	G 1,1/4" -11	50	29,1 x 1,6
PA 540 AOB VA	38	24	1.1/2"	G 1,1/2" -11	60	35,1 x 1,6
PA 550 AOB VA	51	32	2"	G 2" -11	70	48,1 x 1,6

Varianty produktu

PA 500 AOB A	Armatúra k nalisovaniu, DKOR, Oceľ
--------------	------------------------------------