

PA 500 AJ 45 VA

Armatúra k nalisovaniu, DKJ uhol 45°

HANSA FLEX

Vlastnosti

Oblasť použitia	Armatúra k nalisovaniu pre hadice HD 500
Prípojka 1	Závit pre matice UN/UNF
Tvar tesnenia 1	Vnútorý kužeľ 74°
Skratka	DKJ
Norma	ISO 8434-2
Zapojenie	s ochranou proti vytrhnutiu (Interlock)
Rozsah dodávky	Vsuvka k nalisovaniu + objímka k nalisovaniu
Materiál	Ušľachtilá oceľ

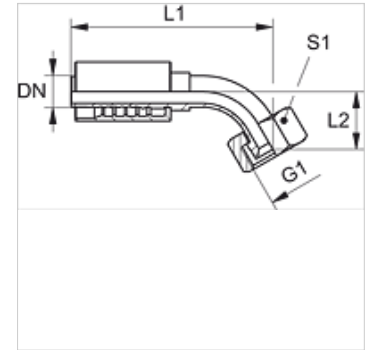

Výrobok

Označenie	DN	Rozmer	Clo	G1	L2 (mm)	S1
PA 520 AJ 45 VA	19	12	3/4"	1.1/16" -12 UN	37,5	32
PA 520 AJ 25 45 VA	19	12	3/4"	1,5/16" -12 UN	43,5	41
PA 525 AJ 45 VA	25	16	1"	1,5/16" -12 UN	47,0	41
PA 525 AJ 32 45 VA	25	16	1"	1,5/8" -12 UN	51,0	50
PA 532 AJ 45 VA	31	20	1.1/4"	1,5/8" -12 UN	49,0	50
PA 532 AJ 40 45 VA	31	20	1.1/4"	1,7/8" -12 UN	52,0	60
PA 540 AJ 45 VA	38	24	1.1/2"	1,7/8" -12 UN	50,0	60
PA 540 AJ 50 45 VA	38	24	1.1/2"	2,1/2" -12 UN	-	70
PA 550 AJ 45 VA	51	32	2"	2,1/2" -12 UN	78,0	70