

PA 500 AOJ 45 A

Armatúra k nalisovaniu, DKOJ uhol 45°

HANSA FLEX

Vlastnosti

Oblasť použitia	Armatúra k nalisovaniu pre hadice HD 500
Prípojka 1	Závit pre matice UN/UNF
Tvar tesnenia 1	Vnútorňý kužeľ 74° s O-krúžkom
Skratka	DKOJ
Norma	ISO 8434-2
Zapojenie	s ochranou proti vytrhnutiu (Interlock)
Rozsah dodávky	Vsuvka k nalisovaniu + objímka k nalisovaniu
Materiál	Oceľ
Povrchová ochrana	galvanický povlak

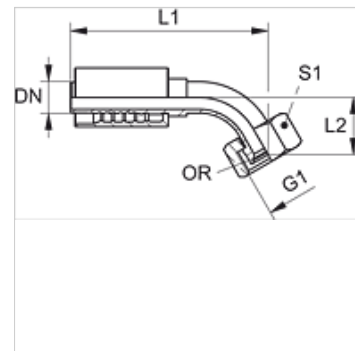

Výrobok

Označenie	DN	Rozmer	Clo	Prevádzkový tlak (bar)	G1	L1 (mm)	L2 (mm)	S1	OR
PA 720 AOJ 45	19	12	3/4"	-	1.1/16" -12 UN	140,0	34,5	32	19,00 x 1,50
PA 725 AOJ 45	25	16	1"	-	1,5/16" -12 UN	169,5	39,0	41	25,00 x 1,50
PA 532 AOJ 45 A	31	20	1.1/4"	420,0	1,5/8" -12 UN	199,0	49,5	50	31,47 x 1,78
PA 540 AOJ 45 A	38	24	1.1/2"	420,0	1,7/8" -12 UN	233,0	58,0	55	37,82 x 1,78
PA 550 AOJ 45 A	51	32	2"	345,0	2,1/2" -12 UN	275,0	64,0	75	50,00 x 2,00