

# PA 500 AOJ 90 A

Armatúra k nalisovaniu, DKOJ uhol 90°

**HANSA FLEX**

## Vlastnosti

<b>Oblasť použitia</b>	Armatúra k nalisovaniu pre hadice HD 500
<b>Prípojka 1</b>	Závit pre matice UN/UNF
<b>Tvar tesnenia 1</b>	Vnútrotný kužeľ 74° s O-krúžkom
<b>Skratka</b>	DKOJ
<b>Norma</b>	ISO 8434-2
<b>Zapojenie</b>	s ochranou proti vytrhnutiu (Interlock)
<b>Rozsah dodávky</b>	Vsuvka k nalisovaniu + objímka k nalisovaniu
<b>Materiál</b>	Oceľ
<b>Povrchová ochrana</b>	galvanický povlak

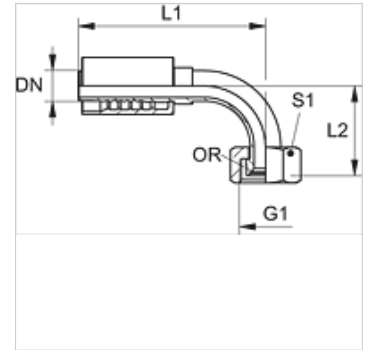

## Výrobok

Označenie	DN	Rozmer	Clo	Prevádzkový tlak (bar)	G1	L1 (mm)	L2 (mm)	S1	OR
PA 720 AOJ 90	19	12	3/4"	-	1.1/16" -12 UN	127,5	68,2	32	19,00 x 1,50
PA 725 AOJ 90	25	16	1"	-	1,5/16" -12 UN	158,0	81,7	41	25,00 x 1,50
PA 532 AOJ 90 A	31	20	1.1/4"	420,0	1,5/8" -12 UN	182,0	104,0	50	31,47 x 1,78
PA 540 AOJ 90 A	38	24	1.1/2"	420,0	1,7/8" -12 UN	215,5	120,5	55	37,82 x 1,78
PA 550 AOJ 90 A	51	32	2"	345,0	2,1/2" -12 UN	250,5	140,0	75	50,00 x 2,00