

PA 500 AOS 45 A

Armatúra k nalisovaniu, DKOS uhol 45°

HANSA FLEX

Vlastnosti

Oblasť použitia	Armatúra k nalisovaniu pre hadice HD 500
Prípojka 1	metrický závit pre matice
Tvar tesnenia 1	Vonkajší kužeľ 24° s O-kružkom
Skratka	DKOS
Norma	ISO 8434-1
Zapojenie	s ochranou proti vytrhnutiu (Interlock)
Rozsah dodávky	Vsuvka k nalisovaniu + objímka k nalisovaniu
Materiál	Oceľ
Povrchová ochrana	galvanický povlak

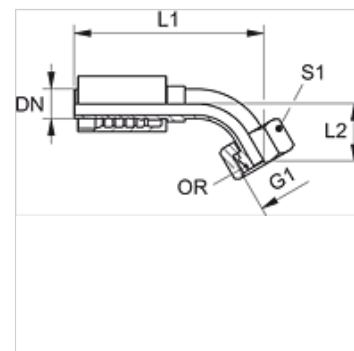

Výrobok

Označenie	DN	Rozmer	Clo	G1	pre vonkajší Ø rúrky (mm)	L1 (mm)	L2 (mm)	S1	OR
PA 720 AOS 16 45	19	12	3/4"	M 30 x 2	20	133,0	27,0	36	16,0 x 2,5
PA 720 AOS 45	19	12	3/4"	M 36 x 2	25	136,0	30,0	46	20,0 x 2,5
PA 720 AOS 25 45	19	12	3/4"	M 42 x 2	30	142,0	35,0	50	27,0 x 2,5
PA 725 AOS 20 45	25	16	1"	M 36 x 2	25	156,5	34,5	41	22,0 x 2,5
PA 725 AOS 45	25	16	1"	M 42 x 2	30	164,0	34,5	50	25,0 x 2,5
PA 725 AOS 32 45	25	16	1"	M 52 x 2	38	170,0	41,0	60	33,0 x 2,5
PA 532 AOS 25 45 A	31	20	1"	M 42 x 2	30	175,0	39,5	50	27,0 x 2,5
PA 532 AOS 45 A	31	20	1.1/4"	M 52 x 2	38	192,5	41,0	60	33,0 x 2,5

Varianty produktu

PA 500 AOS 45 VA Armatúra k nalisovaniu, DKOS uhol 45°, Ušľachtilá oceľ