

PA 700 AOS

Armatúra k nalisovaniu, DKOS

HANSA FLEX

Vlastnosti

Oblasť použitia	Armatúra k nalisovaniu pre hadice HD 700
Prípojka 1	metrický závit pre matice
Tvar tesnenia 1	Vonkajší kužeľ 24° s O-kružkom
Skratka	DKOS
Norma	ISO 8434-1
Zapojenie	s ochranou proti vytrhnutiu (Interlock)
Rozsah dodávky	Vsuvka k nalisovaniu + objímka k nalisovaniu
Materiál	Oceľ
Povrchová ochrana	galvanický povlak

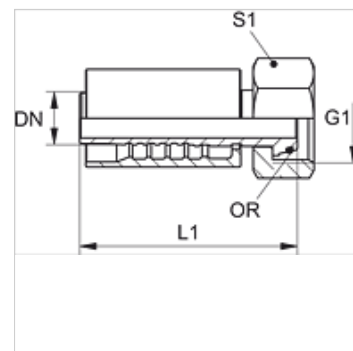

Výrobok

Označenie	DN	Rozmer	Clo	Prevádzkový tlak (bar)	G1	pre vonkajší Ø rúrky (mm)	S1	L1 (mm)	OR
PA 710 AOS 08	10	6	3/8"	630,0	M 20 x 1,5	-	24	-	10,0 x 1,5
PA 710 AOS	10	6	3/8"	630,0	M 22 x 1,5	14	27	67,6	12,0 x 2,0
PA 713 AOS	12	8	1/2"	420,0	M 24 x 1,5	16	30	72,8	13,0 x 2,0
PA 713 AOS 16	12	8	1/2"	420,0	M 30 x 2	20	36	75,8	17,5 x 2,5
PA 716 AOS 13	16	10	5/8"	420,0	M 24 x 1,5	16	30	83,5	13,0 x 2,0
PA 716 AOS	16	10	5/8"	420,0	M 30 x 2	20	36	86,0	17,5 x 2,5
PA 716 AOS 20	16	10	5/8"	420,0	M 36 x 2	25	41	89,0	20,0 x 2,5
PA 720 AOS 16	19	12	3/4"	420,0	M 30 x 2	20	36	96,0	16,0 x 2,5
PA 720 AOS	19	12	3/4"	420,0	M 36 x 2	25	46	99,0	20,0 x 2,5
PA 720 AOS SW41	19	12	3/4"	420,0	M 36 x 2	25	41	99,0	20,0 x 2,5
PA 720 AOS 25	19	12	3/4"	420,0	M 42 x 2	30	50	100,0	25,0 x 2,5
PA 725 AOS 20	25	16	1"	420,0	M 36 x 2	25	46	112,0	20,0 x 2,5
PA 725 AOS	25	16	1"	420,0	M 42 x 2	30	50	113,0	25,0 x 2,5
PA 725 AOS 32	25	16	1"	420,0	M 52 x 2	38	60	131,0	33,0 x 2,5
PA 732 AOS 25 S	31	20	1.1/4"	420,0	M 42 x 2	30	50	151,0	27,0 x 2,5
PA 732 AOS S	31	20	1.1/4"	420,0	M 52 x 2	38	60	112,5	33,0 x 2,5
PA 740 AOS 32	38	24	1.1/2"	420,0	M 52 x 2	38	60	136,5	33,0 x 2,5

Varianty produktu

PA 700 AOS VA Armatúra k nalisovaniu, DKOS, Ušľachtilá oceľ