

# PA 700 SF 45

Armatúra k nalisovaniu, SFL uhol 45°

**HANSA FLEX**

## Vlastnosti

<b>Oblasť použitia</b>	Armatúra k nalisovaniu pre hadice HD 700
<b>Prípojka 1</b>	Prírubová prípojka SAE 3000 PSI
<b>Tvar tesnenia 1</b>	s plochým tesnením s O-krúžkom SF
<b>Skratka</b>	SFL
<b>Norma</b>	SAE J518 ISO 6162-1
<b>Zapojenie</b>	s ochranou proti vytrhnutiu (Interlock)
<b>Rozsah dodávky</b>	Vsuvka k nalisovaniu + objímka k nalisovaniu
<b>Materiál</b>	Oceľ
<b>Povrchová ochrana</b>	galvanický povlak

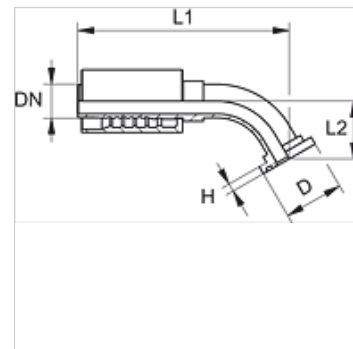

## Výrobok

Označenie	DN	Rozmer	Člo	Veľkosť príruby	Prevádzkový tlak (bar)	D: (mm)	V (mm)	L1 (mm)	L2 (mm)
PA 713 SF 45	12	8	1/2"	1/2"	350,0	30,2	6,7	94,5	22,5
PA 713 SF 20 45	12	8	1/2"	3/4"	350,0	38,1	6,7	126,0	26,5
PA 720 SF 45	19	12	3/4"	3/4"	350,0	38,1	6,8	132,5	27,5
PA 720 SF 25 45	19	12	3/4"	1"	320,0	44,5	8,1	134,5	29,5
PA 725 SF 20 45	25	16	1"	3/4"	320,0	38,1	6,8	153,0	30,0
PA 725 SF 45	25	16	1"	1"	320,0	44,5	8,1	159,0	28,5
PA 725 SF 32 45	25	16	1"	1.1/4"	280,0	50,8	8,1	161,0	30,5
PA 732 SF 25 45 S	31	20	1.1/4"	1"	280,0	44,5	8,0	170,5	35,0
PA 732 SF 45 S	31	20	1.1/4"	1.1/4"	280,0	50,8	8,0	181,5	41,5
PA 732 SF 40 45 S	31	20	1.1/4"	1.1/2"	210,0	60,3	8,0	188,0	43,5
PA 740 SF 32 45	38	24	1.1/2"	1.1/4"	210,0	50,8	8,1	199,5	42,0
PA 740 SF 45	38	24	1.1/2"	1.1/2"	210,0	60,3	8,1	212,5	41,5
PA 740 SF 50 45	38	24	1.1/2"	2"	210,0	71,4	9,6	233,5	58,5

## Varianty produktu

PA 700 SF 45 VA Armatúra k nalisovaniu, SFL uhol 45°, Ušľachtilá oceľ