

PA 700 SF9 45

Armatúra k nalisovaniu, SFS-CAT uhol 45°

HANSA FLEX

Vlastnosti

Oblasť použitia	Armatúra k nalisovaniu pre hadice HD 700
Prípojka 1	Prírubová prípojka SAE 6000 PSI
Tvar tesnenia 1	s plochým tesnením s O-krúžkom SF
Skratka	SFS-CAT
vhodné pre	Caterpillar
Zapojenie	s ochranou proti vytrhnutiu (Interlock)
Rozsah dodávky	Vsuvka k nalisovaniu + objímka k nalisovaniu
Materiál	Oceľ
Povrchová ochrana	galvanický povlak

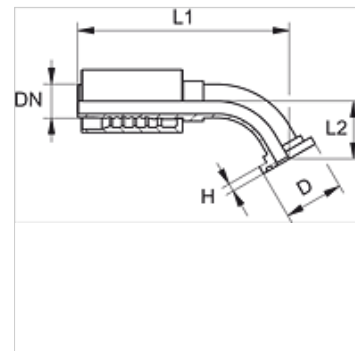

Výrobok

Označenie	DN	Rozmer	Clo	Veľkosť príruby	Prevádzkový tlak (bar)	D: (mm)	V (mm)	L1 (mm)	L2 (mm)
PA 720 SF9 45	19	12	3/4"	3/4"	420,0	41,3	14,2	139,0	34,0
PA 720 SF9 25 45	19	12	3/4"	1"	420,0	47,6	14,2	143,0	37,5
PA 725 SF9 20 45	25	16	1"	3/4"	420,0	41,3	14,2	157,0	35,0
PA 725 SF9 45	25	16	1"	1"	420,0	47,6	14,2	167,0	36,5
PA 725 SF9 32 45	25	16	1"	1.1/4"	420,0	54,0	14,2	172,0	41,5
PA 732 SF9 25 45 S	31	20	1.1/4"	1"	420,0	47,6	14,0	174,0	39,5
PA 732 SF9 45 S	31	20	1.1/4"	1.1/4"	420,0	54,0	14,0	187,0	44,0
PA 732 SF9 40 45 S	31	20	1.1/4"	1.1/2"	420,0	63,5	14,0	195,5	52,0
PA 740 SF9 32 45	38	24	1.1/2"	1.1/4"	420,0	54,0	14,0	205,5	47,0
PA 740 SF9 45	38	24	1.1/2"	1.1/2"	420,0	63,5	14,2	224,0	51,0