

PAY 300 HJ

Armatúra k nalisovaniu, AGJ

HANSA FLEX

Vlastnosti

Prípojka 1	Vonkajší závit UN/UNF
Tvar tesnenia 1	Vonkajší kužeľ 74°
Skratka	AGJ
Norma	ISO 8434-2
Rozsah dodávky	Vsuvka k nalisovaniu + objímka k nalisovaniu
Materiál	Oceľ
Povrchová ochrana	galvanický povlak

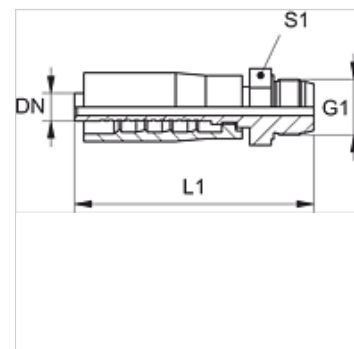

Výrobok

Označenie	DN	Rozmer	Clo	G1	L1 (mm)	S1
PAY 308 HJ 10	8	5	5/16"	9/16" -18 UNF	64,0	17
PAY 308 HJ 13	8	5	5/16"	3/4" -16 UNF	-	-
PAY 316 HJ 20	16	10	5/8"	1.1/16" -12 UN	94,0	30
PAY 320 HJ 25	19	12	3/4"	1,5/16" -12 UN	95,0	36
PAY 325 HJ 32	25	16	1"	1,5/8" -12 UN	97,0	46
PAY 332 HJ 40	31	20	1.1/4"	1,7/8" -12 UN	110,0	50