

# PN AFL VA

Vsuvka k nalisovaniu, DKL

**HANSA FLEX**

## Vlastnosti

|                        |  |
|------------------------|--|
| <b>Oblasť použitia</b> | Vsuvka k nalisovaniu pre hadice HD 100 až HD 400, KP, TE |
| <b>Prípojka 1</b>      | metrický závit pre matice                                |
| <b>Tvar tesnenia 1</b> | 24°/60° Universal sealing head                           |
| <b>Skratka</b>         | DKL  |
| <b>Konštrukčný rad</b> | Ľahká  |
| <b>Materiál</b>        | Ušľachtilá oceľ  |

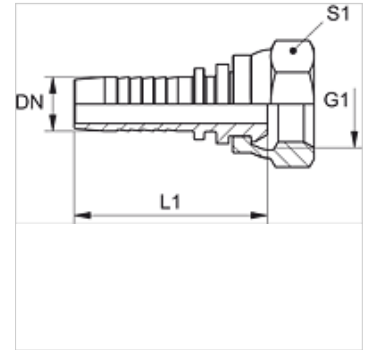

## Poznámka

Príslušnú objímku vyberte podľa typu hadice.

## Výrobok

| Označenie       | DN | Rozmer | Clo    | Prevádzkový tlak (bar) | G1         | pre vonkajší Ø rúrky (mm) | L1 (mm) | S1 |
|-----------------|----|--------|--------|------------------------|------------|---------------------------|---------|----|
| PN 06 AFL 04 VA | 6  | 4      | 1/4"   | 250,0                  | M 12 x 1,5 | 6                         | 49,8    | 14 |
| PN 06 AFL VA    | 6  | 4      | 1/4"   | 250,0                  | M 14 x 1,5 | 8                         | 50,8    | 17 |
| PN 06 AFL 08 VA | 6  | 4      | 1/4"   | 250,0                  | M 16 x 1,5 | 10                        | 50,8    | 19 |
| PN 08 AFL 06 VA | 8  | 5      | 5/16"  | 250,0                  | M 16 x 1,5 | 8                         | 51,8    | 17 |
| PN 08 AFL VA    | 8  | 5      | 5/16"  | 250,0                  | M 16 x 1,5 | 10                        | 51,8    | 19 |
| PN 08 AFL 10 VA | 8  | 5      | 5/16"  | 250,0                  | M 18 x 1,5 | 12                        | 51,8    | 22 |
| PN 10 AFL 08 VA | 10 | 6      | 3/8"   | 250,0                  | M 16 x 1,5 | 10                        | 52,8    | 19 |
| PN 10 AFL VA    | 10 | 6      | 3/8"   | 250,0                  | M 18 x 1,5 | 12                        | 52,8    | 22 |
| PN 13 AFL VA    | 12 | 8      | 1/2"   | 250,0                  | M 22 x 1,5 | 15                        | 55,3    | 27 |
| PN 16 AFL VA    | 16 | 10     | 5/8"   | 160,0                  | M 26 x 1,5 | 18                        | 59,5    | 32 |
| PN 20 AFL VA    | 19 | 12     | 3/4"   | 160,0                  | M 30 x 2   | 22                        | 66,0    | 36 |
| PN 25 AFL VA    | 25 | 16     | 1"     | 100,0                  | M 36 x 2   | 28                        | 73,5    | 41 |
| PN 32 AFL VA    | 31 | 20     | 1.1/4" | 100,0                  | M 45 x 2   | 35                        | 95,0    | 50 |
| PN 40 AFL VA    | 38 | 24     | 1.1/2" | 100,0                  | M 52 x 2   | 42                        | 95,0    | 60 |

## Varianty produktu

PN AFL Vsuvka k nalisovaniu, DKL, Oceľ