

# PN AFS

Vsuvka k nalisovaniu, DKS

**HANSA FLEX**

## Vlastnosti

<b>Oblasť použitia</b>	Vsuvka k nalisovaniu pre hadice HD 100 až HD 400, KP, TE
<b>Prípojka 1</b>	metrický závit pre matice
<b>Tvar tesnenia 1</b>	24°/60° Universal sealing head
<b>Skratka</b>	DKS
<b>Konštrukčný rad</b>	ťažká
<b>Materiál</b>	Oceľ
<b>Povrchová ochrana</b>	galvanický povlak

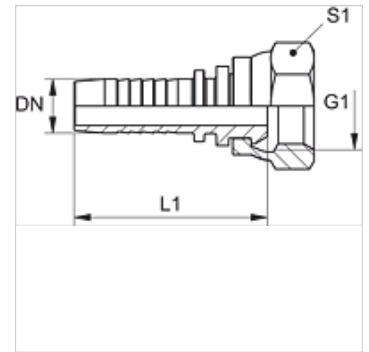

## Poznámka

Príslušnú objímku vyberte podľa typu hadice.

## Výrobok

Označenie	DN	Rozmer	Clo	Prevádzkový tlak (bar)	G1	pre vonkajší Ø rúrky (mm)	L1 (mm)	S1
PN 04 AFS 03	5	3	3/16"	630,0	M 14 x 1,5	6	44,5	17
PN 04 AFS	5	3	3/16"	630,0	M 16 x 1,5	8	44,5	19
PN 06 AFS 04	6	4	1/4"	630,0	M 16 x 1,5	8	51,5	19
PN 06 AFS	6	4	1/4"	630,0	M 18 x 1,5	10	52,5	22
PN 08 AFS 06	8	5	5/16"	630,0	M 18 x 1,5	10	52,5	22
PN 08 AFS	8	5	5/16"	630,0	M 20 x 1,5	12	52,5	24
PN 10 AFS 08	10	6	3/8"	630,0	M 20 x 1,5	12	54,0	24
PN 10 AFS	10	6	3/8"	630,0	M 22 x 1,5	14	57,0	27
PN 13 AFS	12	8	1/2"	400,0	M 24 x 1,5	16	58,0	30
PN 16 AFS	16	10	5/8"	400,0	M 30 x 2	20	66,0	36
PN 20 AFS	19	12	3/4"	400,0	M 36 x 2	25	75,5	46
PN 25 AFS	25	16	1"	250,0	M 42 x 2	30	85,5	50
PN 32 AFS	31	20	1.1/4"	250,0	M 52 x 2	38	98,0	60