

PN AOB

Vsuvka k nalisovaniu, DKOR

HANSA FLEX

Vlastnosti

Oblasť použitia	Vsuvka k nalisovaniu pre hadice HD 100 až HD 400, KP, TE
Prípojka 1	Závit pre matice BSP
Tvar tesnenia 1	Vonkajší kužeľ 60° s O-kružkom
Skratka	DKOR
Norma	ISO 8434-6 BS 5200
Materiál	Oceľ
Povrchová ochrana	galvanický povlak

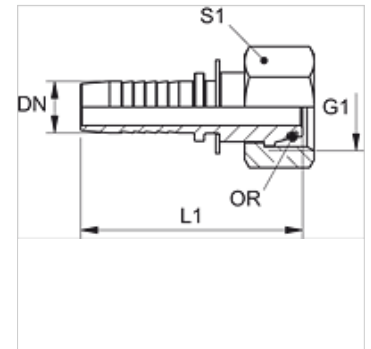

Poznámka

Príslušnú objímku vyberte podľa typu hadice.

Výrobok

Označenie	DN	Rozmer	Clo	Prevádzkový tlak (bar)	G1	L1 (mm)	S1	OR
PN 06 AOB	6	4	1/4"	400,0	G 1/4" -19	44,5	19	6,0 x 1,0
PN 10 AOB	10	6	3/8"	400,0	G 3/8" -19	48,5	22	8,1 x 1,6
PN 13 AOB	12	8	1/2"	350,0	G 1/2" -14	51,0	27	12,1 x 1,6
PN 16 AOB	16	10	5/8"	350,0	G 5/8" -14	54,0	30	13,1 x 1,6
PN 20 AOB	19	12	3/4"	315,0	G 3/4" -14	63,5	32	17,1 x 1,6
PN 25 AOB	25	16	1"	250,0	G 1" -11	75,5	38	22,1 x 1,6
PN 25 AOB 32	25	16	1"	250,0	G 1,1/4" -11	78,0	50	29,1 x 1,6
PN 32 AOB	31	20	1.1/4"	250,0	G 1,1/4" -11	87,0	50	29,1 x 1,6
PN 32 AOB 40	31	20	1.1/4"	210,0	G 1,1/2" -11	88,5	55	35,1 x 1,6
PN 40 AOB	38	24	1.1/2"	210,0	G 1,1/2" -11	92,0	55	35,1 x 1,6
PN 40 AOB 50	38	24	1.1/2"	210,0	G 2" -11	97,0	70	48,1 x 1,6
PN 50 AOB	51	32	2"	210,0	G 2" -11	110,0	70	48,1 x 1,6