

PN HB

Vsuvka k nalisovaniu, AGR

HANSA FLEX

Vlastnosti

Oblasť použitia	Vsuvka k nalisovaniu pre hadice HD 100 až HD 400, KP, TE
Prípojka 1	Vonkajší závit BSP, valcový
Tvar tesnenia 1	Vnútorňý kužeľ 60°
Skratka	AGR
Norma	ISO 8434-6 BS 5200
Materiál	Oceľ
Povrchová ochrana	galvanický povlak

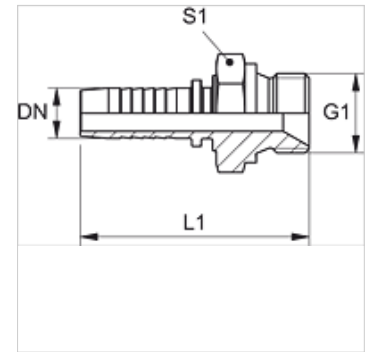

Poznámka

Príslušnú objímku vyberte podľa typu hadice.

Výrobok

Označenie	DN	Rozmer	Clo	Prevádzkový tlak (bar)	G1	L1 (mm)	S1
PN 04 HB	5	3	3/16"	350,0	G 1/8" -28	42,5	14
PN 04 HB 06	5	3	3/16"	350,0	G 1/4" -19	46,0	19
PN 06 HB 02	6	4	1/4"	350,0	G 1/8" -28	48,5	14
PN 06 HB	6	4	1/4"	400,0	G 1/4" -19	52,0	19
PN 06 HB 10	6	4	1/4"	400,0	G 3/8" -19	54,0	22
PN 06 HB 13	6	4	1/4"	350,0	G 1/2" -14	57,5	27
PN 08 HB 06	8	5	5/16"	400,0	G 1/4" -19	52,0	19
PN 08 HB 10	8	5	5/16"	400,0	G 3/8" -19	54,0	22
PN 08 HB 13	8	5	5/16"	350,0	G 1/2" -14	57,5	27
PN 10 HB 02	10	6	3/8"	350,0	G 1/8" -28	50,0	17
PN 10 HB 06	10	6	3/8"	400,0	G 1/4" -19	53,5	19
PN 10 HB	10	6	3/8"	400,0	G 3/8" -19	55,5	22
PN 10 HB 13	10	6	3/8"	350,0	G 1/2" -14	59,5	27
PN 13 HB 10	12	8	1/2"	350,0	G 3/8" -19	56,5	22
PN 13 HB	12	8	1/2"	350,0	G 1/2" -14	60,5	27
PN 13 HB 16	12	8	1/2"	350,0	G 5/8" -14	62,5	30
PN 13 HB 20	12	8	1/2"	250,0	G 3/4" -14	62,5	32
PN 16 HB 13	16	10	5/8"	350,0	G 1/2" -14	65,0	27
PN 16 HB	16	10	5/8"	35,0	G 5/8" -14	67,0	30
PN 16 HB 20	16	10	5/8"	315,0	G 3/4" -14	67,0	32
PN 20 HB	19	12	3/4"	315,0	G 3/4" -14	73,5	32
PN 20 HB 25	19	12	3/4"	250,0	G 1" -11	78,5	41
PN 25 HB	25	16	1"	250,0	G 1" -11	86,5	41
PN 25 HB 32	25	16	1"	250,0	G 1,1/4" -11	87,5	50
PN 32 HB	31	20	1.1/4"	250,0	G 1,1/4" -11	97,0	50
PN 32 HB 40	31	20	1.1/4"	210,0	G 1,1/2" -11	100,0	55
PN 40 HB 32	38	24	1.1/2"	210,0	G 1,1/4" -11	100,5	50
PN 40 HB	38	24	1.1/2"	210,0	G 1,1/2" -11	103,5	55
PN 40 HB 50	38	24	1.1/2"	210,0	G 2" -11	109,0	70
PN 50 HB	51	32	2"	210,0	G 2" -11	124,5	70

Varianty produktu

PN HB VA Vsuvka k nalisovaniu, AGR, Ušľachtaná oceľ