

# PN HJL

Vsuvka k nalisovaniu, JIS

**HANSA FLEX**

## Vlastnosti

<b>Oblasť použitia</b>	Vsuvka k nalisovaniu pre hadice HD 100 až HD 400, KP, TE
<b>Prípojka 1</b>	metrický vonkajší závit valcový
<b>Tvar tesnenia 1</b>	Vonkajší kužeľ 60°
<b>Norma</b>	JIS 8363
<b>vhodné pre</b>	Komatsu
<b>Materiál</b>	Oceľ
<b>Povrchová ochrana</b>	galvanický povlak

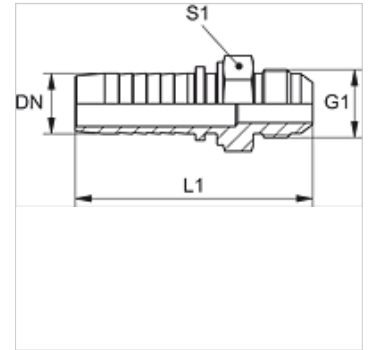

## Poznámka

Príslušnú objímku vyberte podľa typu hadice.

## Výrobok

Označenie	DN	Rozmer	Clo	Prevádzkový tlak (bar)	G1	L1 (mm)	S1
PN 06 HJL	6	4	1/4"	345,0	M 14 x 1,5	57,0	14
PN 06 HJL 08	6	4	1/4"	345,0	M 16 x 1,5	58,0	17
PN 10 HJL 08	10	6	3/8"	345,0	M 16 x 1,5	60,0	17
PN 10 HJL	10	6	3/8"	345,0	M 18 x 1,5	61,5	19
PN 13 HJL	12	8	1/2"	345,0	M 22 x 1,5	66,5	22
PN 13 HJL 16	12	8	1/2"	275,0	M 24 x 1,5	68,5	24
PN 16 HJL	16	10	5/8"	275,0	M 24 x 1,5	73,0	24
PN 20 HJL	19	12	3/4"	275,0	M 30 x 1,5	86,0	30
PN 25 HJL	25	16	1"	205,0	M 33 x 1,5	100,5	36
PN 32 HJL	31	20	1.1/4"	170,0	M 36 x 1,5	112,0	46
PN 40 HJL	38	24	1.1/2"	170,0	M 42 x 1,5	119,0	46