

PN HL

Vsuvka k nalisovaniu, CEL

HANSA FLEX

Vlastnosti

Oblasť použitia	Vsuvka k nalisovaniu pre hadice HD 100 až HD 400, KP, TE
Prípojka 1	metrický vonkajší závit valcový
Tvar tesnenia 1	Vnútorňý kužeľ 24°
Skratka	CEL
Norma	ISO 8434-1
Konštrukčný rad	Ľahká
Materiál	Oceľ
Povrchová ochrana	galvanický povlak

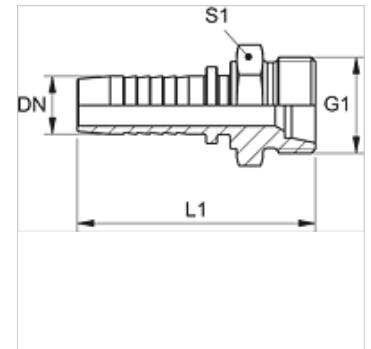

Poznámka

Príslušnú objímku vyberte podľa typu hadice.

Výrobok

Označenie	DN	Rozmer	Clo	G1	pre vonkajší Ø rúrky (mm)	L1 (mm)	S1
PN 04 HL	5	3	3/16"	M 12 x 1,5	6	43,0	14
PN 06 HL 04	6	4	1/4"	M 12 x 1,5	6	49,0	14
PN 06 HL	6	4	1/4"	M 14 x 1,5	8	49,0	17
PN 06 HL 08	6	4	1/4"	M 16 x 1,5	10	50,0	17
PN 06 HL 10	6	4	1/4"	M 18 x 1,5	12	51,0	19
PN 08 HL 06	8	5	5/16"	-	-	-	-
PN 08 HL	8	5	5/16"	M 16 x 1,5	10	50,0	17
PN 08 HL 10	8	5	5/16"	M 18 x 1,5	12	51,0	19
PN 08 HL 13	8	5	5/16"	M 22 x 1,5	15	52,0	24
PN 10 HL 08	10	6	3/8"	M 16 x 1,5	10	52,5	17
PN 10 HL	10	6	3/8"	M 18 x 1,5	12	52,5	19
PN 10 HL 13	10	6	3/8"	M 22 x 1,5	15	53,5	24
PN 13 HL 10	12	8	1/2"	M 18 x 1,5	12	53,5	22
PN 13 HL	12	8	1/2"	M 22 x 1,5	15	54,5	24
PN 13 HL 16	12	8	1/2"	M 26 x 1,5	18	55,5	27
PN 16 HL 13	16	10	5/8"	M 22 x 1,5	15	59,0	24
PN 16 HL	16	10	5/8"	M 26 x 1,5	18	60,0	27
PN 16 HL 20	16	10	5/8"	M 30 x 2	22	62,0	32
PN 20 HL 16	19	12	3/4"	M 26 x 1,5	18	66,5	27
PN 20 HL	19	12	3/4"	M 30 x 2	22	68,5	32
PN 20 HL 25	19	12	3/4"	M 36 x 2	28	70,0	41
PN 25 HL	25	16	1"	M 36 x 2	28	77,5	41
PN 32 HL	31	20	1.1/4"	M 45 x 2	35	91,0	46
PN 40 HL	38	24	1.1/2"	M 52 x 2	42	95,5	55

Varianty produktu

PN HL VA Vsuvka k nalisovaniu, CEL, Ušľachtilá oceľ