

PN HM

Vsuvka k nalisovaniu, AGM-plochá

HANSA FLEX

Vlastnosti

Oblasť použitia	Vsuvka k nalisovaniu pre hadice HD 100 až HD 400, KP, TE
Prípojka 1	metrický vonkajší závit valcový
Tvar tesnenia 1	s plochým tesnením
Skratka	AGM-plochá
Norma	DIN 3852
Materiál	Oceľ
Povrchová ochrana	galvanický povlak

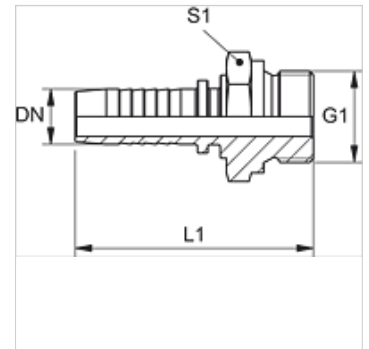

Poznámka

Príslušnú objímku vyberte podľa typu hadice.

Výrobok

Označenie	DN	Rozmer	Clo	G1	L1 (mm)	S1
PN 06 HM 02	6	4	1/4"	M 10 x 1	50,5	14
PN 06 HM	6	4	1/4"	M 14 x 1,5	53,0	19
PN 08 HM	8	5	5/16"	M 16 x 1,5	54,5	22
PN 08 HM 10	8	5	5/16"	M 18 x 1,5	56,0	24
PN 10 HM 08	10	6	3/8"	M 16 x 1,5	55,5	22
PN 10 HM	10	6	3/8"	M 18 x 1,5	57,0	24
PN 13 HM	12	8	1/2"	M 22 x 1,5	59,5	27
PN 16 HM	16	10	5/8"	M 26 x 1,5	65,0	32
PN 20 HM	19	12	3/4"	M 30 x 1,5	74,5	36
PN 25 HM	25	16	1"	M 38 x 1,5	83,0	46
PN 32 HM	31	20	1.1/4"	M 45 x 1,5	95,0	55
PN 40 HM	38	24	1.1/2"	M 52 x 1,5	101,0	60