

# PN HS

Vsuvka k nalisovaniu, CES

**HANSA FLEX**

## Vlastnosti

Oblasť použitia	Vsuvka k nalisovaniu pre hadice HD 100 až HD 400, KP, TE
Prípojka 1	metrický vonkajší závit valcový
Tvar tesnenia 1	Vnútorný kužeľ 24°
Skratka	CES
Norma	ISO 8434-1
Konštrukčný rad	ťažká
Materiál	Oceľ
Povrchová ochrana	galvanický povlak

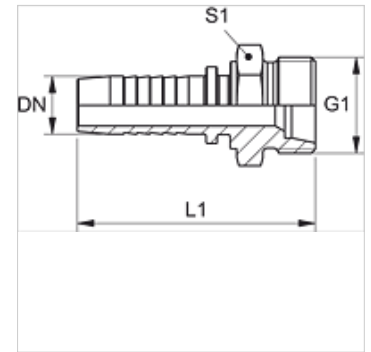

## Poznámka

Príslušnú objímku vyberte podľa typu hadice.

## Výrobok

Označenie	DN	Rozmer	Clo	Prevádzkový tlak (bar)	G1	pre vonkajší Ø rúrky (mm)	L1 (mm)	S1
PN 04 HS	5	3	3/16"	630,0	M 16 x 1,5	8	48,0	17
PN 06 HS 03	6	4	1/4"	630,0	M 14 x 1,5	6	52,0	14
PN 06 HS 04	6	4	1/4"	630,0	M 16 x 1,5	8	54,0	17
PN 06 HS	6	4	1/4"	630,0	M 18 x 1,5	10	54,0	19
PN 08 HS 06	8	5	5/16"	630,0	M 18 x 1,5	10	54,0	19
PN 08 HS	8	5	5/16"	630,0	M 20 x 1,5	12	56,0	22
PN 08 HS 13	8	5	5/16"	420,0	M 24 x 1,5	16	58,0	27
PN 10 HS 06	10	6	3/8"	630,0	M 18 x 1,5	10	55,5	19
PN 10 HS 08	10	6	3/8"	630,0	M 20 x 1,5	12	57,5	22
PN 10 HS	10	6	3/8"	630,0	M 22 x 1,5	14	59,5	24
PN 10 HS 13	10	6	3/8"	420,0	M 24 x 1,5	16	59,5	27
PN 13 HS 10	12	8	1/2"	420,0	M 22 x 1,5	14	60,5	24
PN 13 HS	12	8	1/2"	420,0	M 24 x 1,5	16	60,5	27
PN 13 HS 16	12	8	1/2"	420,0	M 30 x 2	20	64,5	32
PN 16 HS	16	10	5/8"	420,0	M 30 x 2	20	69,0	32
PN 20 HS 16	19	12	3/4"	420,0	M 30 x 2	20	75,5	32
PN 20 HS	19	12	3/4"	420,0	M 36 x 2	25	79,5	36
PN 25 HS 20	25	16	1"	420,0	M 36 x 2	25	87,5	36
PN 25 HS	25	16	1"	420,0	M 42 x 2	30	89,5	46
PN 32 HS	31	20	1.1/4"	345,0	M 52 x 2	38	104,0	55
PN 40 HS 32	38	24	1.1/2"	345,0	M 52 x 2	38	107,5	55

## Varianty produktu

PN HS VA Vsuvka k nalisovaniu, CES, Ušľachtilá oceľ