

# PN SF

Vsuvka k nalisovaniu, SFL

**HANSA FLEX**

## Vlastnosti

<b>Oblasť použitia</b>	Vsuvka k nalisovaniu pre hadice HD 100 až HD 400, KP, TE
<b>Prípojka 1</b>	Prírubová prípojka SAE 3000 PSI
<b>Tvar tesnenia 1</b>	s plochým tesnením s O-krúžkom SF
<b>Skratka</b>	SFL
<b>Norma</b>	SAE J518 ISO 6162-1
<b>Materiál</b>	Oceľ
<b>Povrchová ochrana</b>	galvanický povlak

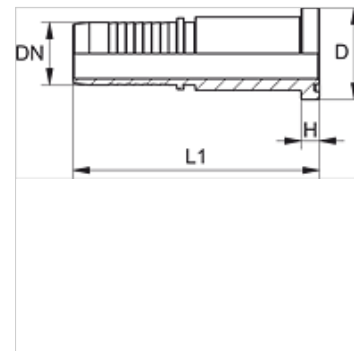

## Poznámka

Príslušnú objímku vyberte podľa typu hadice.

## Výrobok

Označenie	DN	Rozmer	Clo	Veľkosť príruby	Prevádzkový tlak (bar)	D: (mm)	V (mm)	L1 (mm)
PN 13 SF	12	8	1/2"	1/2"	350,0	30,2	6,80	80,5
PN 13 SF 20	12	8	1/2"	3/4"	350,0	38,1	6,80	85,5
PN 16 SF 13	16	10	5/8"	1/2"	350,0	30,2	6,80	85,0
PN 16 SF 20	16	10	5/8"	3/4"	350,0	38,1	6,80	90,0
PN 16 SF 25	16	10	5/8"	1"	320,0	44,4	8,10	97,5
PN 20 SF 13	19	12	3/4"	1/2"	350,0	30,2	6,80	91,0
PN 20 SF	19	12	3/4"	3/4"	350,0	38,1	6,80	96,5
PN 20 SF 25	19	12	3/4"	1"	320,0	44,4	8,10	99,5
PN 25 SF 20	25	16	1"	3/4"	320,0	38,1	6,80	104,5
PN 25 SF	25	16	1"	1"	320,0	44,4	8,10	110,5
PN 25 SF 32	25	16	1"	1.1/4"	280,0	50,8	8,10	113,5
PN 32 SF 25	31	20	1.1/4"	1"	-	44,4	8,10	118,0
PN 32 SF	31	20	1.1/4"	1.1/4"	-	50,8	8,10	125,5
PN 32 SF 40	31	20	1.1/4"	1.1/2"	210,0	60,3	8,10	128,5
PN 40 SF 32	38	24	1.1/2"	1.1/4"	210,0	50,8	8,10	129,0
PN 40 SF	38	24	1.1/2"	1.1/2"	210,0	60,3	8,10	135,0
PN 40 SF 50	38	24	1.1/2"	2"	210,0	71,4	9,60	138,0
PN 50 SF 40	51	32	2"	1.1/2"	210,0	60,3	8,10	149,5
PN 50 SF	51	32	2"	2"	210,0	71,4	9,60	153,0
PN 50 SF 60	51	32	2"	2.1/2"	175,0	84,0	9,60	156,0
PN 60 SF 50	60	40	2.3/8"	2"	175,0	71,4	9,60	155,5
PN 60 SF	60	40	2.3/8"	2.1/2"	175,0	84,1	9,60	158,5
PN 76 SF	76	48	3"	3"	160,0	101,6	9,53	150,0
PN 76 SF 60	76	48	3"	2.1/2"	160,0	84,0	9,53	166,0

## Varianty produktu

PN SF VA Vsuvka k nalisovaniu, SFL, Ušľachtilá oceľ