

PN SF 45 VA

Vsuvka k nalisovaniu, SFL uhol 45°

HANSA FLEX

Vlastnosti

Oblasť použitia	Vsuvka k nalisovaniu pre hadice HD 100 až HD 400, KP, TE
Prípojka 1	Prírubová prípojka SAE 3000 PSI
Tvar tesnenia 1	s plochým tesnením s O-krúžkom SF
Skratka	SFL
Norma	SAE J518 ISO 6162-1
Materiál	Ušľachtilá oceľ

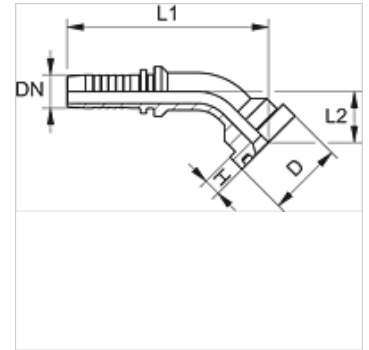

Poznámka

Príslušnú objímku vyberte podľa typu hadice.

Pokyny pre objednanie

NBR tesnenie

FPM (Viton) na vyžiadanie

Výrobok

Označenie	DN	Rozmer	Clo	Veľkosť príruby	Prevádzkový tlak (bar)	D: (mm)	V (mm)	L2 (mm)
PN 13 SF 45 VA	12	8	1/2"	1/2"	350,0	30,2	6,7	30,0
PN 13 SF 20 45 VA	12	8	1/2"	3/4"	350,0	38,1	6,7	34,0
PN 16 SF 13 45 VA	16	10	5/8"	1/2"	350,0	30,2	6,7	34,0
PN 16 SF 20 45 VA	16	10	5/8"	3/4"	350,0	38,1	6,7	34,0
PN 20 SF 45 VA	19	12	3/4"	3/4"	350,0	38,1	6,7	36,0
PN 20 SF 25 45 VA	19	12	3/4"	1"	320,0	44,5	8,0	31,0
PN 25 SF 45 VA	25	16	1"	1"	320,0	44,5	8,0	39,0
PN 25 SF 32 45 VA	25	16	1"	1.1/4"	280,0	50,8	8,0	43,0
PN 32 SF 45 VA	31	20	1.1/4"	1.1/4"	280,0	50,8	8,0	44,0
PN 32 SF 40 45 VA	31	20	1.1/4"	1.1/2"	210,0	60,3	8,0	36,0
PN 40 SF 45 VA	38	24	1.1/2"	1.1/2"	210,0	60,3	8,0	45,0
PN 40 SF 50 45 VA	38	24	1.1/2"	2"	210,0	71,4	9,5	58,0
PN 50 SF 45 VA	51	32	2"	2"	210,0	71,4	9,5	57,0
PN 60 SF 45 VA	60	40	2.3/8"	2.1/2"	175,0	84,1	9,5	-

Varianty produktu

PN SF 45 Vsuvka k nalisovaniu, SFL uhol 45°, Oceľ