

PN SF6

Vsuvka k nalisovaniu, SFS

HANSA FLEX

Vlastnosti

Oblasť použitia	Vsuvka k nalisovaniu pre hadice HD 100 až HD 400, KP, TE
Prípojka 1	Prírubová prípojka SAE 6000 PSI
Tvar tesnenia 1	s plochým tesnením s O-krúžkom SF
Skratka	SFS
Norma	SAE J518 ISO 6162-2
Materiál	Oceľ
Povrchová ochrana	galvanický povlak

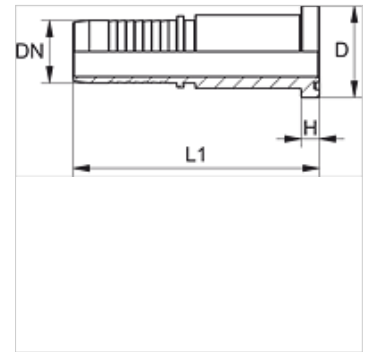

Poznámka

Príslušnú objímku vyberte podľa typu hadice.

Výrobok

Označenie	DN	Rozmer	Clo	Veľkosť príruby	Prevádzkový tlak (bar)	D: (mm)	V (mm)	L1 (mm)
PN 13 SF6	12	8	1/2"	1/2"	420,0	31,8	7,8	81,5
PN 13 SF6 20	12	8	1/2"	3/4"	420,0	41,3	8,8	89,5
PN 16 SF6 13	16	10	5/8"	1/2"	420,0	31,8	7,8	86,0
PN 16 SF6 20	16	10	5/8"	3/4"	420,0	41,3	8,8	97,0
PN 16 SF6 25	16	10	5/8"	1"	420,0	47,6	9,6	104,0
PN 20 SF6 13	19	12	3/4"	1/2"	420,0	31,8	7,8	93,5
PN 20 SF6	19	12	3/4"	3/4"	420,0	41,3	8,8	104,5
PN 20 SF6 25	19	12	3/4"	1"	420,0	47,6	9,6	109,0
PN 25 SF6 20	25	16	1"	3/4"	420,0	41,3	8,8	112,5
PN 25 SF6	25	16	1"	1"	420,0	47,6	9,6	121,5
PN 25 SF6 32	25	16	1"	1.1/4"	420,0	54,0	10,4	126,0
PN 32 SF6 25	31	20	1.1/4"	1"	420,0	47,6	9,6	131,5
PN 32 SF6	31	20	1.1/4"	1.1/4"	420,0	54,0	10,4	138,0
PN 32 SF6 40	31	20	1.1/4"	1.1/2"	420,0	63,5	12,7	142,5
PN 40 SF6	38	24	1.1/2"	1.1/2"	420,0	63,5	12,7	150,5
PN 40 SF6 32	38	24	1.1/2"	1.1/4"	420,0	54,0	10,4	141,5
PN 40 SF6 50	38	24	1.1/2"	2"	420,0	79,4	12,7	155,0
PN 50 SF6	51	32	2"	2"	420,0	79,4	12,7	174,0

Varianty produktu

PN SF6 VA Vsuvka k nalisovaniu, SFS, Ušľachtíľ oceľ