

PN SF6 45

Vsuvka k nalisovaniu, SFS uhol 45°

HANSA FLEX

Vlastnosti

Oblasť použitia	Vsuvka k nalisovaniu pre hadice HD 100 až HD 400, KP, TE
Prípojka 1	Prírubová prípojka SAE 6000 PSI
Tvar tesnenia 1	s plochým tesnením s O-krúžkom SF
Skratka	SFS
Norma	SAE J518 ISO 6162-2
Materiál	Oceľ
Povrchová ochrana	galvanický povlak

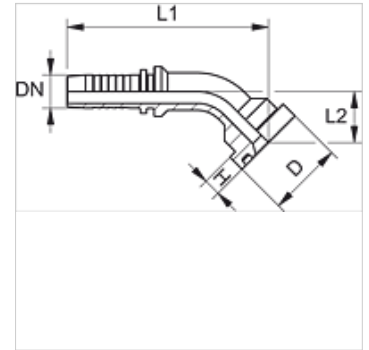

Poznámka

Príslušnú objímku vyberte podľa typu hadice.

Výrobok

Označenie	DN	Rozmer	Clo	Veľkosť príruby	Prevádzkový tlak (bar)	D: (mm)	V (mm)	L1 (mm)	L2 (mm)
PN 13 SF6 45	12	8	1/2"	1/2"	420,0	31,8	7,8	82,0	22,0
PN 13 SF6 20 45	12	8	1/2"	3/4"	420,0	41,3	8,8	87,5	27,5
PN 16 SF6 13 45	16	10	5/8"	1/2"	420,0	31,8	7,8	105,0	29,0
PN 16 SF6 20 45	16	10	5/8"	3/4"	420,0	41,3	8,8	100,5	30,5
PN 16 SF6 25 45	16	10	5/8"	1"	420,0	47,6	9,6	123,0	33,0
PN 20 SF6 45	19	12	3/4"	3/4"	420,0	41,3	8,8	110,0	30,5
PN 20 SF6 25 45	19	12	3/4"	1"	420,0	47,6	9,6	114,5	35,0
PN 25 SF6 20 45	25	16	1"	3/4"	420,0	41,3	8,8	129,0	31,0
PN 25 SF6 45	25	16	1"	1"	420,0	47,6	9,6	137,0	35,5
PN 25 SF6 32 45	25	16	1"	1.1/4"	420,0	54,0	10,4	142,0	40,5
PN 32 SF6 25 45	31	20	1.1/4"	1"	420,0	47,6	9,6	145,0	34,0
PN 32 SF6 45	31	20	1.1/4"	1.1/4"	420,0	54,0	10,4	164,0	44,0
PN 32 SF6 40 45	31	20	1.1/4"	1.1/2"	420,0	63,5	12,7	170,0	50,5
PN 40 SF6 32 45	38	24	1.1/2"	1.1/4"	420,0	54,0	10,4	168,5	44,0
PN 40 SF6 45	38	24	1.1/2"	1.1/2"	420,0	63,5	12,7	190,0	52,0
PN 40 SF6 50 45	38	24	1.1/2"	2"	420,0	79,4	12,7	201,0	63,5
PN 50 SF6 45	51	32	2"	2"	420,0	79,4	12,7	236,0	67,5

Varianty produktu

PN SF6 45 VA Vsuvka k nalisovaniu, SFS uhol 45°, Ušľachtilá oceľ