

## Vlastnosti

<b>Použitie</b>	Vedenia chladiacích a mazacích prostriedkov pre trieskové obrábanie kovov.
<b>Vyhotovenie</b>	Oceľová nosná závitovka s vnútornou hadicou z PVC obojsstranný čap pre naskrutkovanie z ocele Povrch niklovaný
<b>Vlastnosti</b>	Absolútne tesné ručne ohybné takmer v každej polohe stabilné odolné voči olejom, tukom, atď.

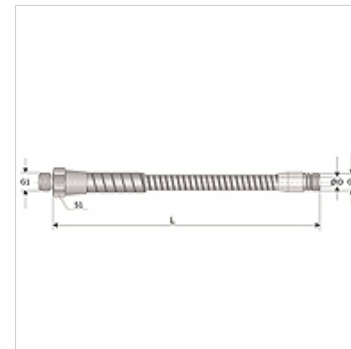

## Pokyny pre objednanie

Iné rozmery na vyžiadanie

## Výrobok

Označenie	G1	G2	ID (mm)	S1 (mm)	Menovitá dĺžka (+/-5 mm)
UPG G1/8-250	R 1/8"	R 1/8"	8,0	15,0	250
UPG G1/8-320	R 1/8"	R 1/8"	8,0	15,0	320
UPG G1/8-400	R 1/8"	R 1/8"	8,0	15,0	400
UPG G1/8-500	R 1/8"	R 1/8"	8,0	15,0	500
UPG G1/4-200	R 1/4"	R 1/4"	10,0	19,0	200
UPG G1/4-250	R 1/4"	R 1/4"	10,0	19,0	250
UPG G1/4-320	R 1/4"	R 1/4"	10,0	19,0	320
UPG G1/4-400	R 1/4"	R 1/4"	10,0	19,0	400
UPG G1/4-500	R 1/4"	R 1/4"	10,0	19,0	500
UPG G1/4-630	R 1/4"	R 1/4"	10,0	19,0	630
UPG G1/4-800	R 1/4"	R 1/4"	10,0	19,0	800
UPG G3/8-200	R 3/8"	R 3/8"	10,0	24,0	200
UPG G3/8-320	R 3/8"	R 3/8"	10,0	24,0	320
UPG G3/8-400	R 3/8"	R 3/8"	10,0	24,0	400
UPG G3/8-500	R 3/8"	R 3/8"	10,0	24,0	500
UPG G3/8-630	R 3/8"	R 3/8"	10,0	24,0	630
UPG G3/8-800	R 3/8"	R 3/8"	10,0	24,0	800
UPG G1/2-500	R 1/2"	R 1/2"	10,0	27,0	500
UPG G1/2-630	R 1/2"	R 1/2"	10,0	27,0	630
UPG G1/2-800	R 1/2"	R 1/2"	10,0	27,0	800