

L HN IN

Hrdlo k naskrutkovaniu, tvar L

HANSA FLEX

Vlastnosti

Prípojka 1	Vonkajší závit NPT
Tvar tesnenia 1	tesniaci závit
Prípojka 2 + 3	Vnútorný závit NPT
Tvar tesnenia 2 + 3	tesniaci závit
Konštrukcia	Hrdlo k zaskrutkovaniu
Vyhotovenie	Tvar L
Materiál	Oceľ
Povrchová ochrana	galvanický povlak

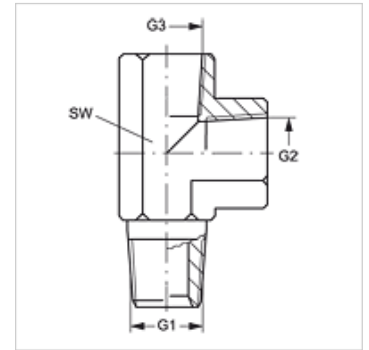

Výrobok

Označenie	G1	G2 + G3	SW (mm)
L HN 02 IN	1/8" -27 NPT	1/8" -27 NPT	14
L HN 04 IN	1/4" -18 NPT	1/4" -18 NPT	19
L HN 06 IN	3/8" -18 NPT	3/8" -18 NPT	22
L HN 08 IN	1/2" -14 NPT	1/2" -14 NPT	27
L HN 12 IN	3/4" -14 NPT	3/4" -14 NPT	33
L HN 16 IN	1" -11,5 NPT	1" -11,5 NPT	41
L HN 20 IN	1,1/4" -11,5 NPT	1,1/4" -11,5 NPT	48

SW = Šírka kľúča