

L HRO HJ

Hrdlo k naskrutkovaniu, tvar L

HANSA FLEX

Vlastnosti

Prípojka 1	Vonkajší závit BSP, valcový
Tvar tesnenia 1	Tvar G
Prípojka 2 + 3	Vonkajší závit UN/UNF
Tvar tesnenia 2 + 3	Vonkajší kužeľ 74°
Konštrukcia	Hrdlo k naskrutkovaniu, priame
Vyhotovenie	Tvar L
Materiál	Oceľ
Povrchová ochrana	galvanický povlak

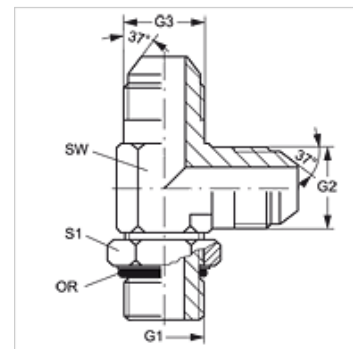

Výrobok

Označenie	G1	G2 + G3	SW (mm)	S1	OR
L HRO 02 HJ 04	G 1/8" -28	7/16" -20 UNF	11	16	7,65 x 1,78
L HRO 02 HJ 05	G 1/8" -28	1/2" -20 UNF	14	16	7,65 x 1,78
L HRO 04 HJ	G 1/4" -19	7/16" -20 UNF	14	20	10,78 x 2,62
L HRO 04 HJ 05	G 1/4" -19	1/2" -20 UNF	14	20	10,78 x 2,62
L HRO 04 HJ 06	G 1/4" -19	9/16" -18 UNF	14	20	10,78 x 2,62
L HRO 04 HJ 08	G 1/4" -19	3/4" -16 UNF	19	20	10,78 x 2,62
L HRO 06 HJ 04	G 3/8" -19	7/16" -20 UNF	19	24	13,94 x 2,62
L HRO 06 HJ 05	G 3/8" -19	1/2" -20 UNF	19	24	13,94 x 2,62
L HRO 06 HJ	G 3/8" -19	9/16" -18 UNF	19	24	13,94 x 2,62
L HRO 06 HJ 08	G 3/8" -19	3/4" -16 UNF	19	24	13,94 x 2,62
L HRO 06 HJ 10	G 3/8" -19	7/8" -14 UNF	22	24	13,94 x 2,62
L HRO 08 HJ 06	G 1/2" -14	9/16" -18 UNF	22	28	17,86 x 2,62
L HRO 08 HJ	G 1/2" -14	3/4" -16 UNF	22	28	17,86 x 2,62
L HRO 08 HJ 10	G 1/2" -14	7/8" -14 UNF	22	28	17,86 x 2,62
L HRO 08 HJ 12	G 1/2" -14	1.1/16" -12 UN	27	28	17,86 x 2,62
L HRO 12 HJ 08	G 3/4" -14	3/4" -16 UNF	27	35	23,47 x 2,62
L HRO 12 HJ	G 3/4" -14	1.1/16" -12 UN	27	35	23,47 x 2,62
L HRO 12 HJ 10	G 3/4" -14	7/8" -14 UNF	27	35	23,47 x 2,62
L HRO 12 HJ 16	G 3/4" -14	1,5/16" -12 UN	27	35	23,47 x 2,62
L HRO 16 HJ 12	G 1" -11	1.1/16" -12 UN	33	43	29,74 x 3,53
L HRO 16 HJ 20	G 1" -11	1,5/8" -12 UN	41	43	29,74 x 3,53
L HRO 20 HJ 16	G 1,1/4" -11	1,5/16" -12 UN	41	52	37,69 x 3,53
L HRO 20 HJ	G 1,1/4" -11	1,5/8" -12 UN	41	52	37,69 x 3,53
L HRO 20 HJ 24	G 1,1/4" -11	1,7/8" -12 UN	48	52	37,69 x 3,53
L HRO 24 HJ	G 1,1/2" -11	1,7/8" -12 UN	48	58	44,04 x 3,53

SW = Šírka kľúča