

T AB HB

Hrdlo k nasrnutkovaniu, tvar T

HANSA FLEX

Vlastnosti

| | |
|---------------------|---|
| Prípojka 1 | Závit pre matice BSP |
| Tvar tesnenia 1 | Vonkajší kužeľ 60° |
| Prípojka 2 + 3 | Vonkajší závit BSP, valcový |
| Tvar tesnenia 2 + 3 | Vnútorný kužeľ 60° |
| Konštrukcia | Hrdlo k nasrnutkovaniu smerovo nastaviteľné |
| Vyhotovenie | Tvar T |
| Materiál | Oceľ |
| Povrchová ochrana | galvanický povlak |

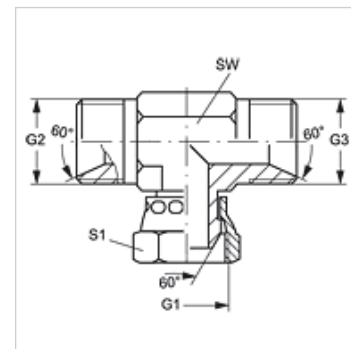

Výrobok

| Označenie | G1 | G2 + G3 | SW (mm) | S1 |
|------------|--------------|--------------|------------|----|
| T AB 04 HB | G 1/4" -19 | G 1/4" -19 | 14 | 19 |
| T AB 06 HB | G 3/8" -19 | G 3/8" -19 | 17 | 22 |
| T AB 08 HB | G 1/2" -14 | G 1/2" -14 | 22 | 27 |
| T AB 10 HB | G 5/8" -14 | G 5/8" -14 | 24 | 30 |
| T AB 12 HB | G 3/4" -14 | G 3/4" -14 | 27 | 32 |
| T AB 16 HB | G 1" -11 | G 1" -11 | 36 | 41 |
| T AB 20 HB | G 1,1/4" -11 | G 1,1/4" -11 | 46 | 50 |
| T AB 24 HB | G 1,1/2" -11 | G 1,1/2" -11 | 50 | 55 |

SW, S1, S2 = Šírka kľúča

Varianty produktu

T AB HB VA Hrdlo k nasrnutkovaniu, tvar T, Ušľachtilá oceľ