

# T AB HB VA

Hrdlo k naskrutkovaniu, tvar T

**HANSA FLEX**

## Vlastnosti

Prípojka 1	Závit pre matice BSP
Tvar tesnenia 1	Vonkajší kužeľ 60°
Prípojka 2 + 3	Vonkajší závit BSP, valcový
Tvar tesnenia 2 + 3	Vnútorý kužeľ 60°
Konštrukcia	Hrdlo k naskrutkovaniu smerovo nastaviteľné
Vyhotovenie	Tvar T
Materiál	Ušľachtilá oceľ

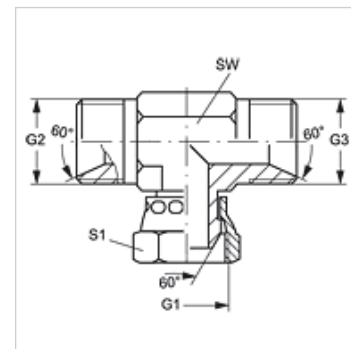

## Výrobok

Označenie	G1	G2 + G3	SW (mm)	S1
T AB 02 HB VA	G 1/8" -28	G 1/8" -28	12	14
T AB 04 HB VA	G 1/4" -19	G 1/4" -19	14	19
T AB 06 HB VA	G 3/8" -19	G 3/8" -19	17	22
T AB 08 HB VA	G 1/2" -14	G 1/2" -14	19	27
T AB 12 HB VA	G 3/4" -14	G 3/4" -14	27	32
T AB 16 HB VA	G 1" -11	G 1" -11	36	41
T AB 20 HB VA	G 1,1/4" -11	G 1,1/4" -11	41	50
T AB 24 HB VA	G 1,1/2" -11	G 1,1/2" -11	50	55

SW, S1, S2 = Šírka kľúča

## Varianty produktu

T AB HB Hrdlo k naskrutkovaniu, tvar T, Oceľ