

T IN HJ

Hrdlo k naskrutkovaniu, tvar T

HANSA FLEX

Vlastnosti

Prípojka 1	Vnútorný závit NPT
Tvar tesnenia 1	tesniaci závit
Prípojka 2 + 3	Vonkajší závit UN/UNF
Tvar tesnenia 2 + 3	Vonkajší kužeľ 74°
Konštrukcia	Hrdlo k privareniu
Vyhotovenie	Tvar T
Materiál	Oceľ
Povrchová ochrana	galvanický povlak

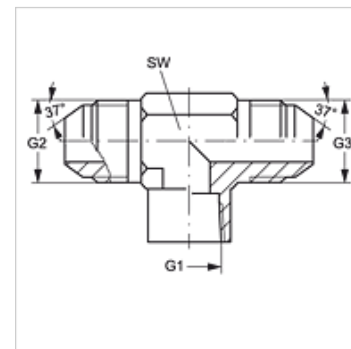

Výrobok

Označenie	G1	G2 + G3	SW (mm)
T IN 02 HJ 04	1/8" -27 NPT	7/16" -20 UNF	14
T IN 02 HJ 05	1/8" -27 NPT	1/2" -20 UNF	14
T IN 04 HJ	1/4" -18 NPT	7/16" -20 UNF	19
T IN 04 HJ 05	1/4" -18 NPT	1/2" -20 UNF	19
T IN 04 HJ 06	1/4" -18 NPT	9/16" -18 UNF	19
T IN 04 HJ 08	1/4" -18 NPT	3/4" -16 UNF	19
T IN 06 HJ	3/8" -18 NPT	9/16" -18 UNF	22
T IN 06 HJ 08	3/8" -18 NPT	3/4" -16 UNF	22
T IN 08 HJ 10	1/2" -14 NPT	7/8" -14 UNF	27
T IN 08 HJ 12	1/2" -14 NPT	1.1/16" -12 UN	27
T IN 12 HJ	3/4" -14 NPT	1.1/16" -12 UN	33
T IN 16 HJ	1" -11,5 NPT	1,5/16" -12 UN	41
T IN 20 HJ	1,1/4" -11,5 NPT	1,5/8" -12 UN	48
T IN 24 HJ	1,1/2" -11,5 NPT	1,7/8" -12 UN	64

SW = Šírka kľúča

Varianty produktu

T IN HJ VA Hrdlo k naskrutkovaniu, tvar T, Ušľachtilá oceľ