

T IN HN

Hrdlo k naskrutkovaniu, tvar T

HANSA FLEX

Vlastnosti

Prípojka 1 Vnútorný závit NPT

Tvar tesnenia 1 tesniaci závit

Prípojka 2 + 3 Vonkajší závit NPT

Tvar tesnenia 2 + 3 tesniaci závit

Konštrukcia Hrdlo k zaskrutkovaniu

Vyhotovenie Tvar T

Materiál Oceľ

Povrchová ochrana galvanický povlak

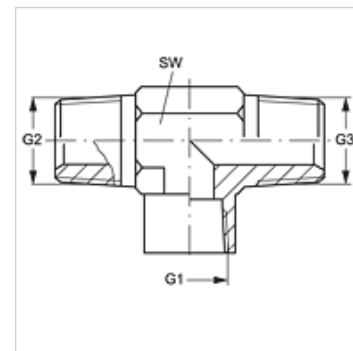

Výrobok

Označenie	G1	G2 + G3	SW (mm)
T IN 02 HN	1/8" -27 NPT	1/8" -27 NPT	14
T IN 04 HN	1/4" -18 NPT	1/4" -18 NPT	19
T IN 06 HN	3/8" -18 NPT	3/8" -18 NPT	22
T IN 08 HN	1/2" -14 NPT	1/2" -14 NPT	27
T IN 12 HN	3/4" -14 NPT	3/4" -14 NPT	33
T IN 16 HN	1" -11,5 NPT	1" -11,5 NPT	41
T IN 20 HN	1,1/4" -11,5 NPT	1,1/4" -11,5 NPT	48

SW = Šírka kľúča