

JG 01 (zyl.)

Konektor k naskrutkovaniu

HANSA FLEX

Vlastnosti

Oblasť použitia	Aplikácie v pneumatických a podtlakových systémoch a v potravinárstve
Prípojka 1	Vonkajší závit BSP, valcový
Tvar tesnenia 1	zapuzdrený O-krúžok na hrdle k naskrutkovaniu
Prípojka 2	Vsuvkové hrdlo
Vyhotovenie	priame
Konštrukcia	Konektor k naskrutkovaniu
Farba	čierny
Médiá	Vzduch kvapalné médiá inertné plyny napr. N ₂ /CO ₂
Materiál	Teleso z kopolyméru etylén vinylacetát, O-krúžok z nitrilu

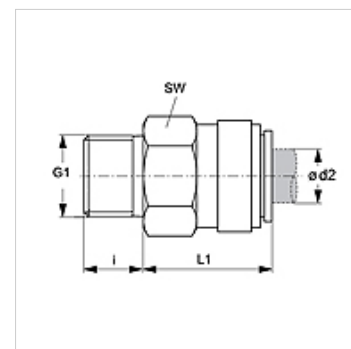

Výrobok

Označenie	Ø d2 (mm)	G1	i (mm)	L1 (mm)	SW (mm)
JG 01 04 11 E	4	G 1/8" -28	5,5	17	14
JG 01 04 12 E	4	G 1/4" -19	8,0	16	17
JG 01 05 11 E	5	G 1/8" -28	5,5	17	14
JG 01 05 12 E	5	G 1/4" -19	8,0	16	17
JG 01 06 11 E	6	G 1/8" -28	5,5	20	15
JG 01 06 12 E	6	G 1/4" -19	8,0	16	17
JG 01 08 11 E	8	G 1/8" -28	5,5	20	17
JG 01 08 12 E	8	G 1/4" -19	8,0	16	17
JG 01 08 13 E	8	G 3/8" -19	9,5	16	22
JG 01 10 12 E	10	G 1/4" -19	8,0	23	20
JG 01 10 13 E	10	G 3/8" -19	9,5	19	22
JG 01 10 14 E	10	G 1/2" -14	12,5	18	27
JG 01 12 13 E	12	G 3/8" -19	9,5	21	24
JG 01 12 14 E	12	G 1/2" -14	12,5	22	27
JG 01 15 14 E	15	G 1/2" -14	12,5	26	27
JG 01 18 14 E	18	G 1/2" -14	12,5	46	30
JG 01 22 16 E	22	G 3/4" -14	15,0	46	32

Príslušenstvo

JG 19 E	Ochranné veko pre násuvnú spojku
JG 18 S	Poistný krúžok pre násuvnú spojku