

LM-DI PT

Potravinárske tesnenie, PTFE

HANSA FLEX

Vlastnosti

Použitie	Tesniaci krúžok pre potravinárske závitové hrdlo
Vyhotovenie	jednostranne sploštený tesniaci krúžok
Norma	DIN 11851
Materiál	PTFE
Rozsah teplôt	od -200 °C do 260 °C

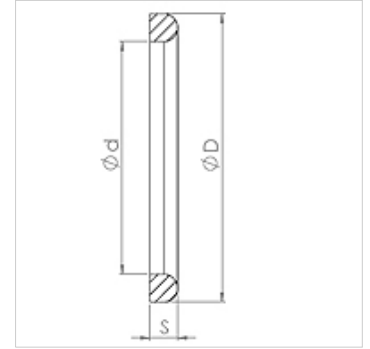

Pokyny pre objednanie

Iné vyhotovenia na vyžiadanie

Výrobok

Označenie	DN	D: (mm)	d (mm)	S (mm)
LM-DI 010 PT	10	20,0	12,0	4,5
LM-DI 013 PT	13	26,0	18,0	4,5
LM-DI 020 PT	20	33,0	23,0	4,5
LM-DI 025 PT	25	40,0	30,0	5,0
LM-DI 032 PT	32	46,0	36,0	5,0
LM-DI 040 PT	40	52,0	42,0	5,0
LM-DI 050 PT	50	64,0	54,0	5,0
LM-DI 065 PT	65	81,0	71,0	5,0
LM-DI 080 PT	80	95,0	85,0	5,0
LM-DI 100 PT	100	114,0	104,0	6,0

tvorí náhradný diel pre nasledujúce produkty

TUEG LMH VA Nákrutka na mlieko, AG, s hladkým hrdlom, ušľachtilá oceľ