

# DDEM P

Piestové tesnenie, DDEM-P

**HANSA FLEX**

## Vlastnosti

Konštrukcia	Drážkový krúžok piestu
Prevádzkový tlak	do 16 bar
Rýchlosť kĺzania max.	1,0 m/s
Vyhotovenie	Metrický
Teplota min.	-30 °C
Teplota max.	80 °C
Médiá	Vzduch
Montáž	na jednodielnych piestoch A na viacdielnych piestoch B
Materiál	90° Shore A PUR
Použitie	Hydraulika + pneumatika



Toleranz / Tolerance		
D	d	L
H9 / e8	h9	+0,50 0

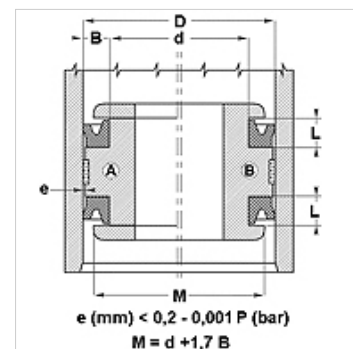

$e \text{ (mm)} < 0,2 - 0,001 P \text{ (bar)}$   
 $M = d + 1,7 B$

## Popis

tesnenie s nízkym trením.  
Jednoduché riešenie.

## Pokyny pre objednanie

Tesnenia s priemerom 20 až 510 mm môžeme vyhotoviť v krátkom čase.

## Výrobok

Označenie	D: (mm)	d (mm)	L (mm)
DDEM 20 14-P	20	14	4,5
DDEM 25 17-P	25	17	5,5
DDEM 32 24-P	32	24	6,0
DDEM 40 30-P	40	30	7,5
DDEM 50 40-P	50	40	7,5
DDEM 55 45-P	55	45	7,5
DDEM 60 50-P	60	50	7,5
DDEM 63 53-P	63	53	7,5
DDEM 65 55-P	65	55	7,5
DDEM 70 58-P	70	58	9,5
DDEM 75 63-P	75	63	9,5
DDEM 80 68-P	80	68	9,5
DDEM 85 73-P	85	73	9,5
DDEM 90 78-P	90	78	9,5
DDEM 000 88-P	100	88	9,5
DDEM 100 95-P	110	95	11,0
DDEM 201 05-P	120	105	11,0
DDEM 25 110-P	125	110	11,0
DDEM 60 145-P	160	145	11,0
DDEM 80 160-P	180	160	15,0
DDEM 00 180-P	200	180	15,0