

Vlastnosti

| | |
|-----------------------|---|
| Konštrukcia | Stierač |
| Rýchlosť kĺzania max. | 0,5 m/s |
| Teplota min. | -30 °C |
| Teplota max. | 80 °C |
| Médiá | Minerálne oleje |
| Montáž | Stierku tvarujte do formy obličky a zatlačte do upínacej drážky |
| Použitie | Hydraulika |
| Materiál | PUR |

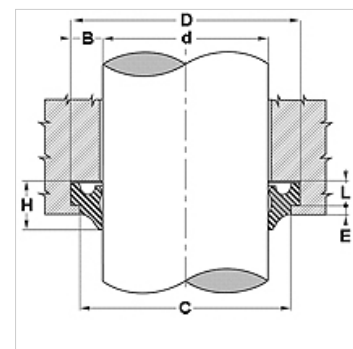

| Toleranz / Tolerance | | | | | | |
|----------------------|-----|------------|-----|-----|------------|--|
| d | D | L | C | F | G | |
| h11 | H11 | +0,20 0 | H10 | H11 | +0,20 0 | |



Popis

stiera aj únikový olej z uteseného priestoru
jednoduchá montáž

Výrobok

| Označenie | D: (mm) | d (mm) | D (mm) | C (mm) | F (mm) | G (mm) | E (mm) | V (mm) |
|------------|------------|-----------|-----------|-----------|-----------|-----------|-----------|-----------|
| DSR 18-UP | 26 | 18 | 4,0 | 24 | 21,5 | 6,0 | 2 | 8 |
| DSR 22-UP | 22 | 22 | 4,0 | 28 | 25,5 | 6,0 | 2 | 8 |
| DSR 32-UP | 40 | 32 | 4,0 | 38 | 35,5 | 6,0 | 2 | 8 |
| DSR 35-UP | 43 | 35 | 4,0 | 41 | 38,5 | 6,0 | 2 | 8 |
| DSR 36-UP | 44 | 36 | 4,0 | 42 | 39,5 | 6,0 | 2 | 8 |
| DSR 40-UP | 48 | 40 | 4,0 | 46 | 43,5 | 6,0 | 2 | 8 |
| DSR 45-UP | 53 | 45 | 4,0 | 51 | 48,5 | 6,0 | 2 | 8 |
| DSR 50-UP | 58 | 50 | 4,0 | 56 | 53,5 | 6,0 | 2 | 8 |
| DSR 55-UP | 63 | 55 | 4,0 | 61 | 58,5 | 6,0 | 2 | 8 |
| DSR 56-UP | 64 | 56 | 4,0 | 62 | 59,5 | 6,0 | 2 | 8 |
| DSR 60-UP | 68 | 60 | 4,0 | 66 | 63,5 | 6,0 | 2 | 8 |
| DSR 63-UP | 71 | 63 | 4,0 | 69 | 66,5 | 6,0 | 2 | 8 |
| DSR 80-UP | 88 | 80 | 4,0 | 86 | 83,5 | 6,0 | 2 | 8 |
| DSR 90-UP | 98 | 90 | 4,0 | 96 | 93,5 | 6,0 | 2 | 8 |
| DSR 100-UP | 108 | 100 | 4,0 | 106 | 103,5 | 6,0 | 2 | 8 |