

Vlastnosti

| | |
|-----------------------|--|
| Konštrukcia | Stierač |
| Rýchlosť kĺzania max. | 0,5 m/s |
| Teplota min. | -30 °C |
| Teplota max. | 100 °C |
| Médiá | Minerálne oleje Vodné emulzie |
| Montáž | lisuje sa do otvorenej drážky |
| Materiál | (1) Puzdro: Oceľ (2) Stierka: 90° Shore A NBR |
| Použitie | Hydraulika |

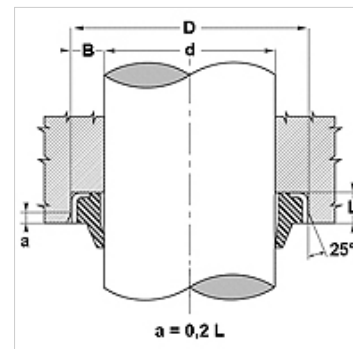

| Toleranz / Tolerance | | |
|----------------------|----|------------|
| d | D | L |
| h11 | H8 | +0,20 0 |



Popis

Malá potreba miesta
žiadne prenikanie nečistôt cez vonkajší kovový krúžok.
Jednoduché riešenie.

Pokyny pre objednanie

V prípade špeciálnych prevádzkových podmienok (kvapalina, teplota, tlak ...) sa prosím obráťte na nás.
Možný iný materiál: FPM

Výrobok

| Označenie | d (mm) | D: (mm) | D: (mm) | D (mm) | V (mm) | Drážky podľa |
|------------|-----------|------------|------------|-----------|-----------|--------------|
| GA 10 16-3 | 10 | 16,0 | - | 3,0 | 4,5 | - |
| GA 10 19-3 | 10 | 18,9 | - | 2,9 | 5,0 | - |
| GA 10 20-5 | 10 | 20,0 | - | 5,0 | 8,0 | - |
| GA 12 18-3 | 12 | 18,0 | - | 3,5 | 5,0 | - |
| GA 12 20-4 | 12 | 20,0 | - | 4,0 | 6,0 | - |
| GA 12 22-5 | 12 | 22,0 | - | 5,0 | 8,0 | - |
| GA 14 20-3 | 14 | 20,0 | - | 3,0 | 4,5 | - |
| GA 14 22-3 | 14 | 22,0 | - | 3,0 | 4,0 | - |
| GA 16 22-3 | 16 | 22,0 | - | 3,0 | 4,0 | - |
| GA 16 26-5 | 16 | 26,0 | - | 5,0 | 8,0 | - |
| GA 18 28-5 | 18 | 28,0 | - | 5,0 | 7,0 | - |
| GA 18 28-7 | 18 | 28,0 | - | 7,0 | 10,0 | ISO 5597 |
| GA 20 26-3 | 20 | 26,0 | - | 3,5 | 5,0 | - |
| GA 20 28-3 | 20 | 28,0 | - | 3,5 | 5,0 | - |
| GA 20 28-5 | 20 | 28,0 | - | 5,0 | 7,0 | - |
| GA 20 30-4 | 20 | 30,0 | - | 4,0 | 6,0 | - |
| GA 20 30-5 | 20 | 30,0 | - | 5,0 | 8,0 | - |
| GA 20 30-7 | 20 | 30,0 | - | 7,0 | 10,0 | ISO 5597 |
| GA 20 35-7 | 20 | 35,0 | - | 7,0 | 10,0 | - |
| GA 22 28-5 | 22 | 28,0 | - | 5,0 | 9,0 | - |
| GA 22 30-4 | 22 | 30,0 | - | 4,0 | 7,0 | - |
| GA 22 32-5 | 22 | 32,0 | - | 5,0 | 7,0 | - |
| GA 22 32-7 | 22 | 32,0 | - | 7,0 | 10,0 | ISO 5597 |
| GA 22 35-5 | 22 | 35,0 | - | 5,0 | 8,0 | - |
| GA 25 35-5 | 25 | 35,0 | - | 5,0 | 8,0 | - |
| GA 25 35-7 | 25 | 35,0 | - | 7,0 | 10,0 | ISO 5597 |
| GA 28 38-5 | 28 | 38,0 | - | 5,0 | 8,0 | - |
| GA 28 38-7 | 28 | 38,0 | - | 7,0 | 10,0 | - |
| GA 28 40-7 | 28 | 40,0 | - | 7,0 | 10,0 | - |
| GA 30 40-5 | 30 | 40,0 | - | 5,0 | 8,0 | - |
| GA 30 40-7 | 30 | 40,0 | - | 7,0 | 10,0 | - |
| GA 30 45-5 | 30 | 45,0 | - | 5,0 | 8,0 | - |
| GA 32 40-4 | 32 | 40,0 | - | 4,0 | 7,0 | - |
| GA 32 42-5 | 32 | 42,0 | - | 5,0 | 7,0 | - |
| GA 32 42-7 | 32 | 42,0 | - | 7,0 | 10,0 | - |
| GA 32 45-4 | 32 | 45,0 | - | 4,0 | 8,0 | - |
| GA 32 45-7 | 32 | 45,0 | - | 7,0 | 10,0 | - |
| GA 33 43-5 | 33 | 43,0 | - | 5,0 | 8,0 | - |



Výrobok

| Označenie | d (mm) | D: (mm) | D: (mm) | D (mm) | V (mm) | Drážky podľa |
|---------------|-----------|------------|------------|-----------|-----------|--------------|
| GA 35 45-5 | 35 | 45,0 | - | 5,0 | 8,0 | - |
| GA 35 45-7 | 35 | 45,0 | - | 7,0 | 10,0 | ISO 5597 |
| GA 35 47-7 | 35 | 47,0 | - | 7,0 | 10,0 | - |
| GA 36 45-7 | 36 | 45,0 | - | 7,0 | 10,0 | - |
| GA 36 46-5 | 36 | 46,0 | - | 5,0 | 8,0 | - |
| GA 3747 - 5 | 37 | - | 47 | 5,0 | - | - |
| GA 38 48-7 | 38 | 48,0 | - | 7,0 | 10,0 | - |
| GA 40 50-5 | 40 | 50,0 | - | 5,0 | 8,0 | - |
| GA 40 50-7 | 40 | 50,0 | - | 7,0 | 10,0 | ISO 5597 |
| GA 40 52-5 | 40 | 52,0 | - | 5,0 | 8,0 | - |
| GA 42 52-7 | 42 | 52,0 | - | 7,0 | 10,0 | - |
| GA 45 55-7 | 45 | 55,0 | - | 7,0 | 10,0 | ISO 5597 |
| GA 45 60-7 | 45 | 60,0 | - | 7,0 | 10,0 | - |
| GA 48 60-7 | 48 | 60,0 | - | 7,0 | 10,0 | - |
| GA 50 56-5 | 50 | 56,0 | - | 5,0 | 8,0 | - |
| GA 50 60-5 | 50 | 60,0 | - | 5,0 | 8,0 | - |
| GA 50 60-7 | 50 | 60,0 | - | 7,0 | 10,0 | ISO 5597 |
| GA 50 65-5 | 50 | 65,0 | - | 5,0 | 8,0 | - |
| GA 50 65-7 | 50 | 65,0 | - | 7,0 | 10,0 | - |
| GA 52 62-7 | 52 | 62,0 | - | 7,0 | 10,0 | - |
| GA 55 63-7 | 55 | 63,0 | - | 7,0 | 10,0 | - |
| GA 55 65-7 | 55 | 65,0 | - | 7,0 | 10,0 | - |
| GA 55 70-7 | 55 | 70,0 | - | 7,0 | 10,0 | - |
| GA 55 80-5 | 55 | 80,0 | - | 5,0 | 8,0 | - |
| GA 56 65-7 | 56 | 65,0 | - | 7,0 | 10,0 | - |
| GA 56 66-5 | 56 | 66,0 | - | 5,0 | 8,0 | - |
| GA 56 66-7 | 56 | 66,0 | - | 7,0 | 10,0 | ISO 5597 |
| GA 60 70-5 | 60 | 70,0 | - | 5,0 | 7,0 | - |
| GA 60 70-7 | 60 | 70,0 | - | 7,0 | 10,0 | - |
| GA 60 74-5 | 60 | 74,0 | - | 5,0 | 8,0 | - |
| GA 60 75-7 | 60 | 75,0 | - | 7,0 | 10,0 | - |
| GA 63 75-7 | 63 | 75,0 | - | 7,0 | 10,0 | - |
| GA 63 83-5 | 63 | 83,0 | - | 5,0 | 8,0 | - |
| GA 65 75-7 | 65 | 75,0 | - | 7,0 | 10,0 | - |
| GA 70 80-5 | 70 | 80,0 | - | 5,0 | 7,0 | - |
| GA 70 80-7 | 70 | 80,0 | - | 7,0 | 10,0 | ISO 5597 |
| GA 75 85-7 | 75 | 85,0 | - | 7,0 | 10,0 | - |
| GA 75 87-5 | 75 | 87,0 | - | 5,0 | 7,0 | - |
| GA 80 90-7 | 80 | 90,0 | - | 7,0 | 10,0 | ISO 5597 |
| GA 85 95-7 | 85 | 95,0 | - | 7,0 | 10,0 | - |
| GA 90 100-5 | 90 | 100,0 | - | 5,0 | 7,0 | - |
| GA 90 100-7 | 90 | 100,0 | - | 7,0 | 10,0 | ISO 5597 |
| GA 95 105-7 | 95 | 105,0 | - | 7,0 | 10,0 | - |
| GA 100 110-5 | 100 | 110,0 | - | 5,0 | 7,0 | - |
| GA 100 110-7 | 100 | 110,0 | - | 7,0 | 10,0 | - |
| GA 105 115-7 | 105 | 115,0 | - | 7,0 | 10,0 | - |
| GA 110 120-7 | 110 | 120,0 | - | 7,0 | 10,0 | - |
| GA 115 125-7 | 115 | 125,0 | - | 7,0 | 10,0 | - |
| GA 120 130-7 | 120 | 130,0 | - | 7,0 | 10,0 | - |
| GA 125 140-7 | 125 | 140,0 | - | 7,0 | 10,0 | - |
| GA 125 140-9 | 125 | 140,0 | - | 9,0 | 12,0 | ISO 5597 |
| GA 130 145-9 | 130 | 145,0 | - | 9,0 | 12,0 | - |
| GA 135 145-7 | 135 | 145,0 | - | 7,0 | 10,0 | - |
| GA 135 150-9 | 135 | 150,0 | - | 9,0 | 12,0 | - |
| GA 140 150-7 | 140 | 150,0 | - | 7,0 | 10,0 | - |
| GA 140 155-9 | 140 | 155,0 | - | 9,0 | 12,0 | ISO 5597 |
| GA 150 165-9 | 150 | 165,0 | - | 9,0 | 12,0 | - |
| GA 160 175-9 | 160 | 175,0 | - | 9,0 | 12,0 | ISO 5597 |
| GA 170 185-10 | 170 | 185,0 | - | 10,0 | 14,0 | - |
| GA 180 195-10 | 180 | 195,0 | - | 10,0 | 14,0 | - |
| GA 200 220-12 | 200 | 220,0 | - | 12,0 | 16,0 | - |