

Vlastnosti

Konštrukcia	Stieracie tesnenie tyče
Prevádzkový tlak	do 10 bar
Rýchlosť kĺzania max.	1,0 m/s
Teplota min.	-30 °C
Teplota max.	90 °C
Médiá	Minerálne oleje Voda-vzduch
Montáž	v otvorených drážkach B
Materiál	75° Shore A NBR
Použitie	Pneumatika

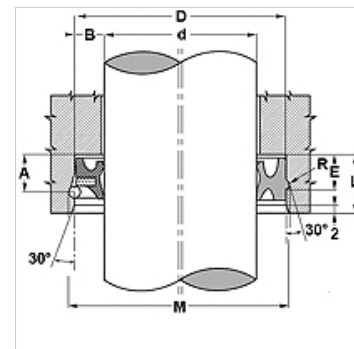

Toleranz / Tolerance				
d	D	M	A	E
H8 / f8	H10	± 0,10	+0,20 0	+0,25 0



Popis

tesnenie s nízkym trením.

Kombinovaný prvok tesnenie-stierka

Výrobok

Označenie	d (mm)	D: (mm)	h (mm)	V (mm)	M (mm)	A: (mm)	R (mm)
NPSL 16 26-7	16	26	7,0	9,5	28,00	8,50	1,10
NPSL 18 26-6	18	26	6,0	8,5	28,00	7,50	1,10
NPSL 20 30-7	20	30	7,0	9,5	32,00	8,80	1,40
NPSL 22 32-7	22	32	7,0	9,5	34,50	8,80	1,40
NPSL 25 35-7	25	35	7,0	9,5	37,50	8,80	1,40
NPSL 30 40-7	30	40	7,0	9,5	42,50	8,80	1,40
NPSL 32 42-7	32	42	7,0	9,5	44,50	8,80	1,40
NPSL 40 50-7	40	50	7,0	9,5	52,50	8,80	1,40