

Vlastnosti

Konštrukcia	Stierač
Rýchlosť kĺzania max.	4,0 m/s
Teplota min.	-30 °C
Teplota max.	110 °C
Médiá	Minerálne oleje
Montáž	Stierku zatlačte do upínacej drážky
Materiál	Stierka: PA + MoS2
Použitie	Hydraulika

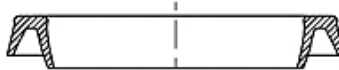

Toleranz / Tolerance			
d	D	L	C
h11	+0,20 0	+0,25 0	+0,10 0

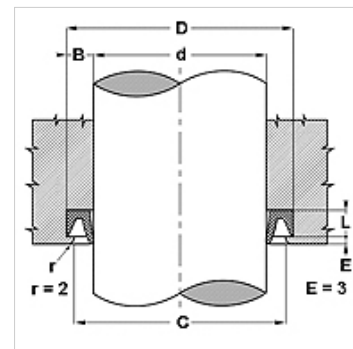

Popis

jednoduchá montáž
Jednoduché riešenie.
Vysoká a odolnosť voči oteru

Výrobok

Označenie	d (mm)	D: (mm)	D (mm)	C (mm)
NW 500	12,70	22,22	4,4	20,62
NW 16	16,00	26,00	4,5	24,50
NW 750	19,05	31,75	6,0	30,15
NW 20	20,00	33,00	6,0	31,50
NW 875	22,22	34,92	6,0	33,32
NW 25	25,00	38,00	6,0	36,50
NW 1000	25,40	38,10	6,0	36,50
NW 1125	28,57	41,27	6,0	99,70
NW 1250	31,80	44,45	6,0	72,29
NW 1500	38,10	50,80	6,0	49,20
NW 1750	44,45	57,15	6,0	52,37
NW 50	50,00	63,00	6,0	61,50
NW 2000	50,80	63,50	6,0	61,90
NW 2500	63,50	76,20	6,0	74,60
NW 2750	69,85	82,55	6,0	80,65
NW 70	70,00	83,00	6,0	81,50
NW 3000	76,20	88,90	6,0	87,30