

Vlastnosti

Konštrukcia	Drážkový krúžok tyče
Prevádzkový tlak	do 400 bar
Rýchlosť kĺzania max.	0,5 m/s
Teplota min.	-30 °C
Teplota max.	80 °C
Médiá	Minerálne oleje
Montáž	v otvorených drážkach B V uzavretých drážkach V otvorených priestoroch na zabudovanie
Materiál	PUR
Použitie	Hydraulika

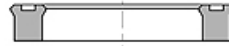

Druck bar	Spaltmaß / Clearance			
	e (mm)			
	TS-TS...L		TS...-AI-TS...-LA	
	d<60mm	d>60mm	d<60mm	d>60mm
50	<0,40	<0,50	<0,60	<0,80
100	<0,30	<0,40	<0,60	<0,80
200	<0,20	<0,30	<0,40	<0,60
300	<0,15	<0,20	<0,30	<0,40
400	<0,10	<0,15	<0,20	<0,30
500			<0,10	<0,15

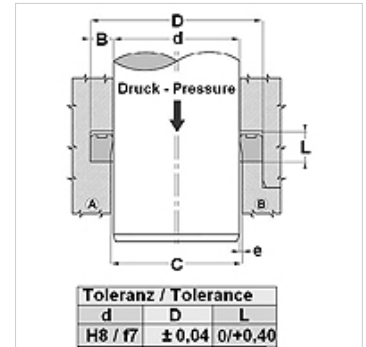

Toleranz / Tolerance		
d	D	L
H8 / f7	± 0,04	0/+0,40

Popis

Vysoká a odolnosť voči oteru
Veľmi dobrý tesniaci účinok pri nízkom tlaku.
Rýchle zmeny zaťaženia.

Pokyny pre objednanie

Tesnenia s priemerom 20 až 510 mm môžeme vyhotoviť v krátkom čase.

Výrobok

Označenie	d (mm)	D: (mm)	D (mm)
TS 12 18	12	18,0	5,0
TS 16 22	16	22,0	4,5
TS 16 24-1	16	24,0	7,0
TS 18 25	18	25,0	5,7
TS 20 25	20	25,0	3,5
TS 20 25-1	20	25,0	4,5
TS 20 26	20	26,0	6,0
TS 20 27	20	27,0	6,5
TS 20 30	20	30,0	8,0
TS 20 30-1	20	30,0	9,0
TS 20 30-2	20	30,0	11,0
TS 21 27	24	27,0	5,0
TS 22 28	22	28,0	5,0
TS 22 30	22	30,0	8,0
TS 22 32-1	22	32,0	9,0
TS 24 30	24	30,0	5,0
TS 25 32	25	32,0	5,0
TS 25 35	25	35,0	6,0
TS 25 35-2	25	35,0	10,0
TS 25 35-5	25	35,0	11,0
TS 25 36	25	36,0	6,0
TS 30 38	30	38,0	9,0
TS 30 40-1	30	40,0	8,0
TS 32 40	32	40,0	9,0
TS 32 42-1	32	42,0	9,0
TS 32 42-2	32	42,0	11,0
TS 35 43-1	35	43,0	9,0
TS 35 45	35	45,0	8,0
TS 36 44	36	44,0	9,0
TS 38 45	38	45,0	7,0
TS 40 50	40	50,0	7,0
TS 42 53	42	53,0	10,0
TS 45 53-1	45	53,0	7,0
TS 45 53	45	53,0	9,0
TS 46 54	46	54,0	9,0
TS 50 62	50	62,0	11,0
TS 56 66-1	56	66,0	7,5
TS 56 66	56	66,0	11,0



Výrobok

Označenie	d (mm)	D: (mm)	D (mm)
TS 60 70-3	60	70,0	13,0
TS 61 69	61	69,0	9,0
TS 63 71	63	70,0	9,0
TS 66 80	66	80,0	11,0
TS 68 76	68	76,0	9,0
TS 70 80	70	80,0	8,0
TS 70 80-2	70	80,0	13,0
TS 72 78	72	78,0	7,0
TS 76 84	76	84,0	9,0
TS 85 97	85	97,0	9,5
TS 88 96	88	96,0	9,0
TS 90 96	90	96,0	5,5
TS 90 100	90	100,0	7,5
TS 91 99	91	99,0	9,0
TS 107 115	107	115,0	9,0
TS 126 134	126	134,0	9,0
TS 145 153	145	153,0	9,0
TS 147 155	147	155,0	11,0
TS 175 183	175	183,5	9,0
TS 221 229	221	229,5	13,0