

# PA 700 AJF

Armatúra k nalisovaniu, ORFS

**HANSA FLEX**

## Vlastnosti

Oblasť použitia	Armatúra k nalisovaniu pre hadice HD 400
Prípojka 1	Závit pre matice UN/UNF
Tvar tesnenia 1	s plochým tesnením
Skratka	ORFS
Norma	ISO 8434-3
Zapojenie	s ochranou proti vytrhnutiu (Interlock)
Rozsah dodávky	Vsuvka k nalisovaniu + objímka k nalisovaniu
Materiál	Oceľ
Povrchová ochrana	galvanický povlak

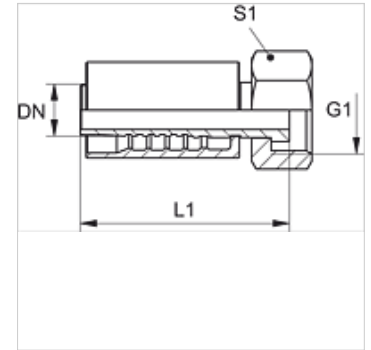

## Výrobok

Označenie	DN	Rozmer	Člo	Prevádzkový tlak (bar)	G1	L1 (mm)	S1
PA 713 AJF	12	8	1/2"	413,0	13/16" -16 UN	65,8	27
PA 716 AJF	16	10	5/8"	413,0	1" -14 UNS	82,0	30
PA 716 AJF 20	16	10	5/8"	413,0	1,3/16" -12 UN	82,0	36
PA 720 AJF	19	12	3/4"	413,0	1,3/16" -12 UN	107,0	36
PA 720 AJF 25	19	12	3/4"	413,0	1,7/16" -12 UN	108,4	41
PA 725 AJF	25	16	1"	413,0	1,7/16" -12 UN	122,0	41