

PA 700 AOS

Armatúra k nalisovaniu, DKOS

HANSA FLEX

Vlastnosti

Oblasť použitia	Armatúra k nalisovaniu pre hadice HD 400
Prípojka 1	metrický závit pre matice
Tvar tesnenia 1	Vonkajší kužeľ 24° s O-kružkom
Skratka	DKOS
Norma	ISO 8434-1
Zapojenie	s ochranou proti vytrhnutiu (Interlock)
Rozsah dodávky	Vsuvka k nalisovaniu + objímka k nalisovaniu
Materiál	Oceľ
Povrchová ochrana	galvanický povlak
Konštrukčný rad	ťažká

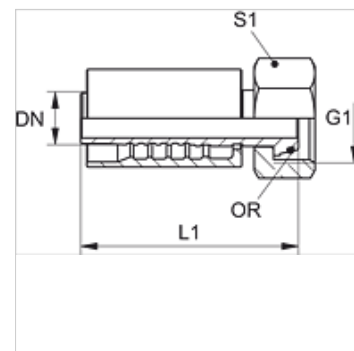

Výrobok

Označenie	DN	Rozmer	Clo	Prevádzkový tlak (bar)	G1	pre vonkajší Ø rúrky (mm)	L1 (mm)	S1	OR
PA 710 AOS 08	10	6	3/8"	630,0	M 20 x 1,5	12	-	24	10,0 x 1,5
PA 710 AOS	10	6	3/8"	630,0	M 22 x 1,5	14	67,6	27	12,0 x 2,0
PA 713 AOS	12	8	1/2"	420,0	M 24 x 1,5	16	72,8	30	13,0 x 2,0
PA 713 AOS 16	12	8	1/2"	420,0	M 30 x 2	20	75,8	36	17,5 x 2,5
PA 716 AOS 13	16	10	5/8"	420,0	M 24 x 1,5	16	83,5	30	13,0 x 2,0
PA 716 AOS	16	10	5/8"	420,0	M 30 x 2	20	86,0	36	17,5 x 2,5
PA 716 AOS 20	16	10	5/8"	420,0	M 36 x 2	25	89,0	46	20,0 x 2,5
PA 720 AOS 16	19	12	3/4"	420,0	M 30 x 2	20	96,0	36	17,5 x 2,5
PA 720 AOS	19	12	3/4"	420,0	M 36 x 2	25	99,0	46	20,0 x 2,5
PA 720 AOS 25	19	12	3/4"	420,0	M 42 x 2	30	100,0	50	27,0 x 2,5
PA 725 AOS 20	25	16	1"	420,0	M 36 x 2	25	112,0	46	22,0 x 2,5
PA 725 AOS	25	16	1"	420,0	M 42 x 2	30	113,0	50	25,0 x 2,5
PA 725 AOS 32	25	16	1"	420,0	M 52 x 2	38	131,0	60	33,0 x 2,5