

WA LMA VA

Pripojovací diel ... LMA, VA

HANSA FLEX

Vlastnosti

Oblasť použitia	Pripojovacia armatúra pre kovové hadice
Prípojka 1	Hrdlo kužeľa, tvar SD s drážkovou presuvnou maticou tvaru F F
Tvar tesnenia 1	tesniaci na kužeľ s tesniacim krúžkom
Norma	DIN 11851 DIN 405-1
Vyhotovenie	priame
Materiál	Ušľachtilá oceľ

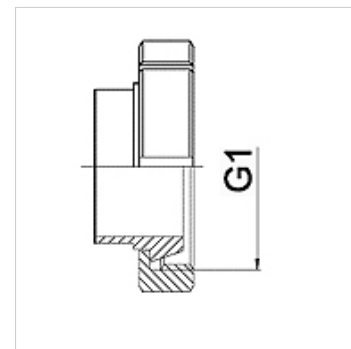

Pokyny pre objednanie

Iné vyhotovenia na vyžiadanie

Výrobok

Označenie	DN	PN (bar)	G1
WA 010 LMAVA	10	40	Rd 28 x 1/8"
WA 013 LMAVA	13	40	Rd 34 x 1/8"
WA 020 LMAVA	20	40	Rd 44 x 1/6"
WA 025 LMAVA	25	40	Rd 52 x 1/6"
WA 032 LMAVA	32	40	Rd 58 x 1/6"
WA 040 LMAVA	40	40	Rd 65 x 1/6"
WA 050 LMAVA	50	25	Rd 78 x 1/6"
WA 065 LMAVA	65	25	Rd 95 x 1/6"
WA 080 LMAVA	80	25	Rd 110 x 1/4"
WA 100 LMAVA	100	25	Rd 130 x 1/4"
WA 125 LMAVA	125	16	Rd 160 x 1/4"
WA 150 LMAVA	150	16	Rd 190 x 1/4"