

PAY 500 HS

Armatúra k nalisovaniu, CES

HANSA FLEX

Vlastnosti

Prípojka 1	metrický vonkajší závit valcový
Tvar tesnenia 1	Vnútný kužeľ 24°
Skratka	CES
Norma	ISO 8434-1
Rozsah dodávky	Vsuvka k nalisovaniu + objímka k nalisovaniu
Materiál	Oceľ
Povrchová ochrana	galvanický povlak

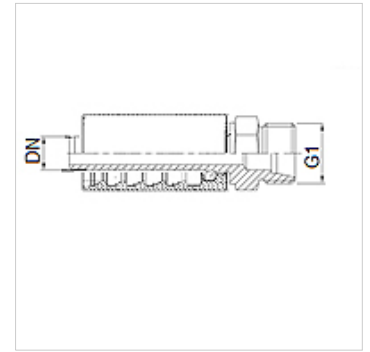

Výrobok

Označenie	DN	Rozmer	Clo	G1	pre vonkajší Ø rúrky (mm)
PAY 506 HS	6	4	1/4"	M 18 x 1,5	10
PAY 508 HS	8	5	5/16"	M 20 x 1,5	12
PAY 510 HS 08	10	3	3/8"	M 20 x 1,5	12
PAY 510 HS	10	6	3/8"	M 22 x 1,5	14
PAY 513 HS	12	8	1/2"	M 24 x 1,5	16
PAY 516 HS	16	10	5/8"	M 30 x 2	20
PAY 520 HS	19	12	3/4"	M 36 x 2	25
PAY 525 HS	25	16	1"	M 42 x 2	30