

Vlastnosti

Prípojka 1	Pevná príruha v úrovni tlaku PN16
Vyhotovenie	priame
Tvar tesnenia 1	s plochým tesnením
Oblasť použitia	Priemysel
Norma	DIN EN 1092-1
Materiál	Ušľachtilá oceľ

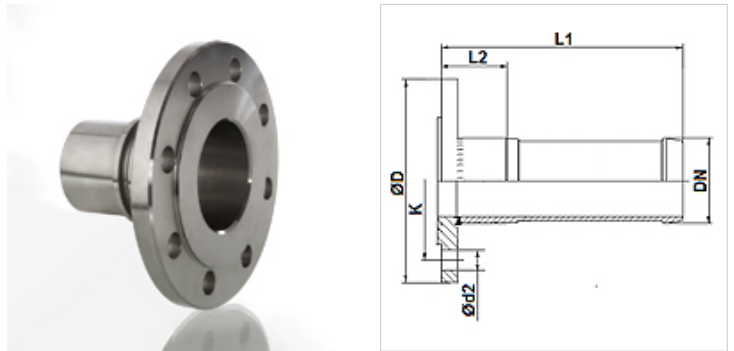

Výrobok

Označenie	DN*	Rozmer	Clo	Ø D (mm)	K (mm)	Ø d2 (mm)	N (mm)
TUE G 25 FF PN16 VA	25	16	1"	115,0	85	14	4
TUE G 32 FF PN16 VA	32	20	1.1/4"	140,0	100	18	4
TUE G 38 FF PN16 VA	40	24	1.1/2"	150,0	110	18	4
TUE G 50 FF PN16 VA	50	32	2"	165,0	125	18	4
TUE G 63 FF PN16 VA	63	40	2.1/2"	-	-	-	-
TUE G 75 FF PN16 VA	75	50	3"	200,0	160	18	8
TUE G 102 FF PN16 VA	100	64	4"	220,0	180	18	8

N = počet otvorov

Príslušenstvo

KS AL	Upínacia miska, hliník
KS FIX AL	Upínacia miska pre kolíkovanie, hliník

Prídavné elementy

FD C4400	Ploché tesnenie
-----------------	-----------------