

K-SCHMUTZFAENGER VA

Strainers

HANSA FLEX

Vlastnosti

Prevádzkový tlak	Max. 40 bar
Prevádzková teplota	max. 180 °C
Popis závitů	G thread acc. to ISO 228-1
Teplota média	max. 180 °C
Filtrovacia vložka	Stainless steel, mesh size 0.6 mm
kryt a hlavica	stainless steel 1.4401/1.4408

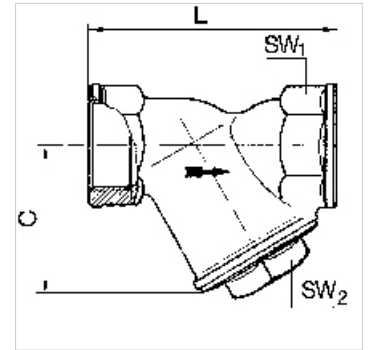
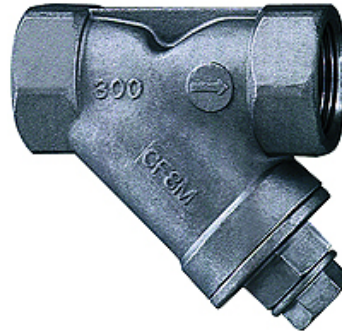

Poznámka

Ďalšie údaje na vyžiadanie.

Výrobok

Označenie	DN	Závit	C (mm)	D (mm)	SW1 (mm)	SW2 (mm)
K- 07 30 25 00	8	G 1/4	47,0	65,0	26	19
K- 07 30 25 01	10	G 3/8	47,0	65,0	26	19
K- 07 30 25 02	15	G 1/2	47,0	65,0	26	19
K- 07 30 25 03	20	G 3/4	60,0	80,0	32	21
K- 07 30 25 04	25	G 1	71,0	90,0	41	27
K- 07 30 25 05	32	G 1 1/4	77,0	105,0	49	28
K- 07 30 25 06	40	G 1 1/2	87,0	120,0	56	32
K- 07 30 25 07	50	G 2	103,0	140,0	69	41