

HK B3/B14 230/400V IE3

Elektromotor B3/B14 230/400V IE3

HANSA FLEX

Vlastnosti

Vyhotovenie Typ konštrukcie B3/B14
Nohy demontovateľné

Krytie IP 55

Teplota okolia -20 °C až +40 °C

Materiál Plášť: Hliník
lakované

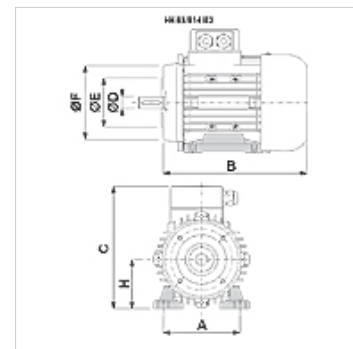

Popis

Motory s kotvou nakrátko s vlastným chladením s úsporou energie

High Efficiency IE3 - IEC60034-30:2009

Menovité napätie 230/400V 50Hz, 460V 60Hz; 4-pólové

Tolerancia napätia +/- 5%

Výrobok

Označenie	n 50 Hz (rpm)	P 50 Hz (kW)	I 50 Hz (A)	LF 50 Hz	V (mm)	A: (mm)	B (mm)	C (mm)	Ø D hriadeľa (mm)	Ø E (mm)	Ø F (mm)	η (IE3) %	Hmotnosť (kg)
HKK 405A 80B4 IE3	1420	0,75	1,80	0,74	80	125	255	209	19	80	120	82,5	13,0
HKK 406A 90SA4 IE3	1445	1,10	2,60	0,74	90	140	280	230	24	95	140	84,1	17,0
HKK 407A 90LB4 IE3	1445	1,50	3,40	0,74	90	140	305	230	24	95	140	85,3	20,0
HKK 408A 100LA4 IE3	1435	2,20	4,70	0,78	100	160	343	256	28	110	160	86,7	27,0
HKK 409A 100LB4 IE3	1435	3,00	6,30	0,78	100	160	343	256	28	110	160	87,7	31,5

P 50 Hz = nominal output at 400 V/50 Hz – n 50 Hz = menovité otáčky pri 400 V/50 Hz – I 50 Hz = Menovitý prúd pri 400 V/50 Hz – LF 50 Hz = Účinník cos phi pri 50 Hz – η (IE3) = efficiency to IE3 in % (at full load)