

# SRWD-VI

Mehko tesnilo za rezni obroč

**HANSA FLEX**

## Lastnosti

**Način izdelave** mehko tesnilo za rezalni prstan

**Material:** FPM ( Viton )

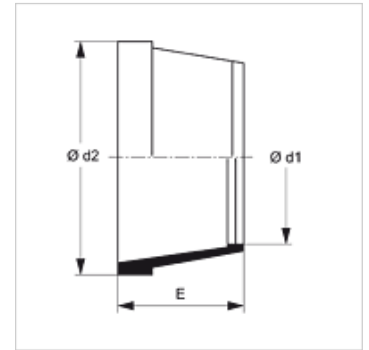

## Navodilo

Dovoljena obratovalna temperatura (Viton): - 25 °C do + 200 °C.

## Artikel

Opis	Serijska	Ø d1 (mm)	Ø d2 (mm)	E (mm)
SRWD 06 VI	L / S	6	9,1	7,3
SRWD 08 VI	L / S	8	8,0	7,3
SRWD 10 VI	L / S	10	13,3	7,3
SRWD 12 VI	L / S	12	15,3	7,0
SRWD 14 VI	S	14	18,8	7,2
SRWD 15 VI	L	15	19,0	7,2
SRWD 16 VI	S	16	20,8	7,5
SRWD 18 VI	L	18	22,8	7,7
SRWD 20 VI	S	20	25,8	9,3
SRWD 22 VI	L	22	26,3	7,9
SRWD 25 VI	S	25	31,5	8,9
SRWD 28 VI	L	28	32,3	8,0
SRWD 30 VI	S	30	37,3	8,2
SRWD 35 VI	L	35	41,3	8,0
SRWD 38 VI	S	38	46,0	8,2
SRWD 42 VI	L	42	48,3	8,2

serijska: LL = zelo lahko L = lahko S = težko – Ø d1 = zunanji premer cevi